

Terminal User Guide

ICT200 Terminal

Yorkshire Payments 2023



www.yorkshirepayments.com

01422 323785

Contents

1. Introduction	1
Thank You	1
This User Guide	1
Security of Your Terminal	1
Caring for Your Terminal	2
Keeping Records	2
Paper Rolls	2
Helpdesk Information	3
Supervisor Password	3
How do I...	4
Quick Installation Checklist	5
2. Your Terminal	7
Terminal Model	7
Terminal Layout	7
Integrated Contactless Reader	8
Contactless Status Lights	8
Terminal Keypad	9
Function Keys	9
Entering the Correct Data	10
Terminal Display	11
Display Icons	12
Menu Screens	13
Paper Loading	14
Terminal Installation	16
“Magic Cable” Installation	17
SIM Card Installation (optional)	18
Telephone Lines and Broadband	19
Inserting a Chip Card	20
Swiping a Card	21
Presenting Contactless Card	22
3. Transactions	23
Performing Transactions	23
Printing the Customer Copy (Duplicate)	23
Contacting High Value Payment (HVP) – Wallet Payments	25
Sales – Inserted Cards (Method One)	26
Sales – Inserted Cards (Method Two)	28
Sales – Contactless Cards	30
Dealing with Contactless Card Read Failures	32
Dealing with Fallback Requests	32

Sales – Swiped Cards	34
Sales with Gratuity (Tip Mode)	35
Sales with Gratuity – Inserted Cards (On Ticket Method)	36
Sales with Gratuity – Inserted Cards (On Screen Method)	38
Sales with Gratuity – Swiped Cards	40
Sales with Cashback	41
Split Bills	42
Surcharging	42
Refunds	43
Mailorder Transactions (Customer Not Present)	45
Mailorder – CSC/AVS Results	45
Mailorder – Sales & Refunds	46
Account Verification	49
Hotel Mode	50
Reversals	51
Duplicate Receipts	51
Cash Advance	52
Balance Enquiry	52
Authorisation Only	53
Forced Transactions	54
Declined Transactions	55
Referrals	56
4. Transaction Receipts	57
Merchant Copy – Signature Transactions	57
Swiped Cards with Signature and Gratuity (Merchant Copy)	58
Inserted Cards with Signature (Merchant Copy)	59
Inserted Cards with Signature and Gratuity (Merchant Copy)	60
Merchant Copy – PIN Transactions	61
Inserted Cards with PIN (Merchant Copy)	61
Inserted Cards with PIN and Gratuity (Merchant Copy)	62
Merchant Copy – Contactless Transactions	63
Contactless Cards (Merchant Copy)	63
Customer Copy – Keyed Transactions	64
Keyed Cards with Signature (Customer Copy)	64
Customer Copy – Keyed Transactions	65
Keyed Cards with Signature (Customer Copy)	65
Customer Copy – Inserted Card	66
Inserted Cards with PIN (Customer Copy)	66
Customer Copy -Contactless	67
Contactless Cards (Customer Copy)	67

Customer Copy – Pre Paid Cards	68
Pre-Paid Cards (Customer Copy)	68
Declined and Void Receipts	69
Transaction Referencing	70
5. Reports	71
End of Day Report	72
Banking Report	73
Example Banking Report (Acquirer 1)	74
Example Banking Report Continued (Acquirer 2)	75
Example Banking Report Continued (Acquirer 2)	76
X Balance Report	77
Z Balance Report	78
Example Z Balance Report (Totals and Breakdown by Issuer)	79
Example Z Balance Report continued (Breakdwon by Waiter and Transaction Listing)	80
Stored Report	81
TMS Report	82
6. Supervisor Functions	83
Supervisor Password	83
Supervisor Password Change (Initial Transaction)	84
Refund Password	84
Supervisor Menus	85
First Supervisor Menu Screen	86
Second Supervisor Menu Screen (Press Menu Once)	86
Third Supervisor Menu Screen (Press Menu Twice)	87
Fourth Supervisor Menu Screen (Press Menu three times)	87
Supervisor Sub-Menus	88
Password Menu	88
First Config Menu	89
Second Config Menu (Press Menu Once)	89
First Shortcut Menu	90
Second Shortcut Menu (Press Menu Once)	90
7. Troubleshooting	91
Frequently Asked Questions	91
Screen Messages	95
Diagnostic Codes	98
Menu Structure	100
8. Notes	101
Certification	101
Operating Environment	102

1. Introduction:

Thank You

Thank you for choosing an Ingenico Payment Terminal.

Your terminal is the Ingenico iCT200 Counter Top Payment Terminal.

Your terminal includes a variety of different functions and features to help you accept credit and debit card transactions in a speedy and efficient manner.

This User Guide

We recommend you thoroughly read this User Guide, together with any other documentation that came with your terminal, as this will help you to quickly make the best use of all the capabilities of your new terminal.

Security of Your Terminal

Upon receipt of your terminal you should check for signs of tampering of the equipment. It is strongly advised that these checks are performed regularly after receipt.

You should check, for example: that the security seals are in place and undamaged; the keypad is firmly in place; that there is no evidence of unusual wires that have been connected to any ports on your terminal or associated equipment, the chip card reader, or any other part of your terminal.

Such checks would provide warning of any unauthorised modifications to your terminal, and other suspicious behaviour of individuals that have access to your terminal.

Your terminal has various tamper evident seals and your terminal detects any interruption to these seals by entering a “tampered state”. In this state the terminal will repeatedly flash the message Alert Irruption! and further use of the terminal will not be possible.

If you observe the Alert Irruption! message, you should contact the terminal Helpdesk immediately.

Caring for Your Terminal

You should take care not to spill liquids on any part of your terminal or any associated parts and equipment.

You should clean the terminal with a soft clean cloth. The magnetic swipe and chip card readers should be cleaned regularly with a suitable cleaning card. To ensure safety, only clean your terminal when it is completely powered off.

Do not use water or cleaning agents on your terminal, doing so may lead to damage. Any damage incurred will be your responsibility and any repair or replacement costs will be charged as appropriate. We therefore recommend that you insure your terminal accordingly.

Keeping Records

Copies of all transaction receipts and your corresponding End of Day reports should be kept together in a safe place (preferably in date order) for a minimum of 6 months, or longer depending on the requirements of the card company.

Paper Rolls

You should only use approved paper rolls as supplied by your terminal supplier. Details on how to contact us to order supplies of paper rolls can be found on the contact sticker on the underside of your terminal. If appropriate, you may also find these details on the inside cover of this User Guide.

Helpdesk Information

Details on how to contact the Terminal Helpdesk can be found in the Quick Start Guide that accompanies your terminal.

You may be asked for your terminal's Terminal Identification Number (TID) or your terminal's Serial Number (S/N).

The TID can be found at the top of each receipt produced by the terminal; and the Serial Number can be found at the top of some reports and on the reverse of your terminal.

Supervisor Password

Your terminal's Supervisor functions can be accessed by means of a Supervisor password, and therefore you are not supplied with a Supervisor Card.

Your terminal is shipped with an initial default password of **01483**, but is configured so that a change of this password is required before you process any transactions.

If you wish to do this before performing a transaction you should refer to the section entitled ***Supervisor Password*** for information on how to change the Supervisor password.

You are strongly advised to ensure that privileged access to your terminal (including access to the Supervisor password) is only granted to staff that have been independently verified as being trustworthy.

How Do I ...

To help you familiarise yourself with your terminal and to understand the basics, below is a list of frequently asked questions about the general operation of your terminal.

- **... set up my terminal?**
Follow the simple step-by-step installation checklist in the next section.
- **... turn my terminal on and off?**
Your terminal is powered on automatically once the power supply unit is plugged into the “Magic Cable” connector unit. The terminal powers off when the power supply is removed.
- **... do a Sale or a Refund?**
Step-by-step instructions for all types of sales and refunds are given in the section entitled *Transactions*, these are provided with screenshots of the terminal.
- **... do my End of Day reports?**
The section entitled *Reports* describes the End of Day procedures. It is important to note that you should perform your End of Day reports at the end of every trading day. This will provide you with a full record of all your transactions and ensure that your funds are processed in the fastest possible time frame.
- **... change my supervisor password?**
Your terminal has a default Supervisor password of **01483**, you are required to change this password before you process any transactions. Instructions on how to do so can be found in the section entitled *Supervisor Password*.
- **... change the paper roll?**
Step-by-step instructions on how to load a new paper roll into your terminal are provided in the section entitled *Paper Loading*.
- **... feed the paper through the terminal?**
Press and hold the clear key when the terminal is displaying the idle screen and the terminal will feed paper through the printer.

- **... get my terminal polled?** Your terminal is an “online” terminal, which means that transactions are captured when you take them so there is no requirement for Polling the terminal. You must however ensure that you do your End of Day reports, to find out more refer to the section entitled *Reports*.
- **... solve any problems?**
If, in the unlikely event that you encounter any problems or have any questions relating to the operation of the terminal, read through the section entitled *Troubleshooting*. If you cannot resolve your problem you should call the terminal Helpdesk.

Quick Installation Checklist

- Before starting to use your terminal, please read all sections of this guide, together with any other documents that came with your terminal, carefully.
- Set up your terminal in a convenient location.
- Plug the power supply unit into a mains socket, and plug the power connector into the power socket on the “Magic Cable” connector unit.
- Plug the telephone lead into the BT socket and the IN socket on the “Magic Cable” connector unit.
- If your telephone system requires a 9 (or similar) to get an outside line, you will need to program this prefix number into your terminal. Refer to the section entitled *Telephone Lines and Broadband* for more details.
- If your terminal has been supplied with a SIM Card, ensure that it is installed into the terminal. Refer to the section entitled *SIM Card Installation* for more details.
- If your terminal has been supplied with an Ethernet cable, then you should plug the Ethernet cable into a DHCP enabled Local Area Network (LAN) and into the ETHERNET socket on the “Magic Cable” connector unit.
- Ensure that a paper roll is in place in your terminal, and load one if this is not already the case.
- Familiarise yourself with the menu structure on your terminal.

- Your default supervisor password is **01483**, you should change this from the default.
- Do an END OF DAY report from the REPORTS menu. This will check that your terminal can connect to and is set up on the Acquirer's Host System. You should refer to the section entitled *Reports* for more details.
- You should contact the terminal Helpdesk if you see any of the following:
 - If you receive a CANNOT CONFIRM result to the Banking section of the report;
 - If a Merchant Number on the Banking section of the report is incorrect;
 - If an Acquirer that you expected to be configured (such as American Express or Diners Club) is not on the Banking section of the report.

Your terminal is now ready to use.

2. Your Terminal

Terminal Model

The Ingenico iCT200 Counter Top Payment Terminal is a compact and ergonomically designed terminal capable of processing card transactions. It is a fixed point terminal that has an integrated “Magic Cable” which enables connection to a telephone line or Local Area Network (LAN); it may also have the option of using a mobile network in order to communicate.

Approximately once a month your terminal will call the Terminal Management System (TMS) to receive any updates to the software, details of new card schemes, and any changes to your configuration. This call will take place automatically, normally outside of standard trading hours and therefore it is important that your terminal is powered on and connected to a telephone line, your network or left in a location with good mobile network signal.

Terminal Layout

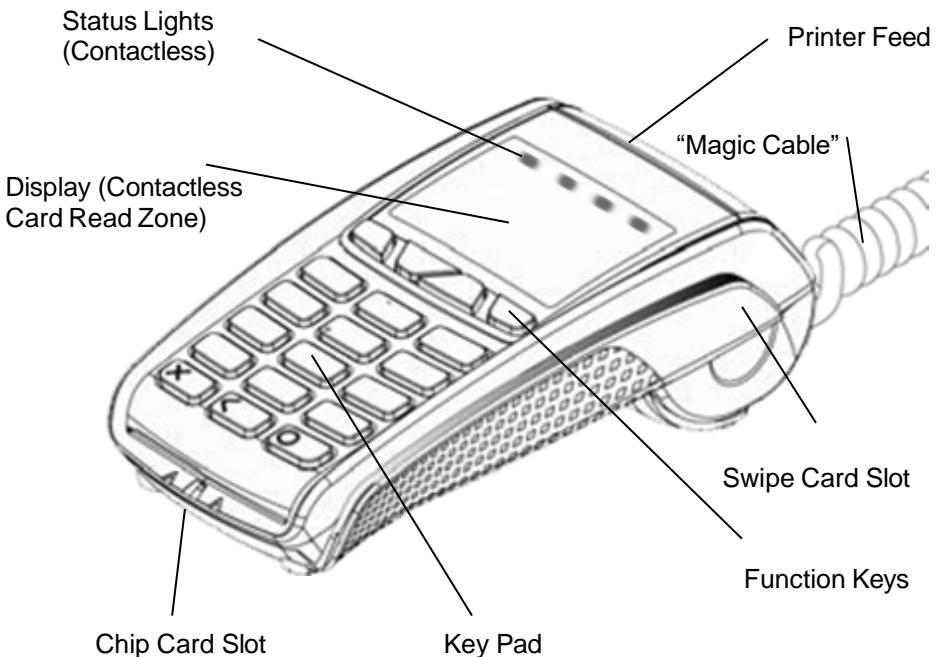

Integrated Contactless Reader

Your terminal (iCT250 model only) includes an integrated contactless reader in order to process contactless transactions.

Contactless Status Lights

Your terminal has a row of four status lights that are visible in the top part of the display if the optional integrated contactless reader is included, and is active.

When in idle mode the first (left hand) status light will flash periodically (approximately every 5 seconds); this indicates that your terminal is in idle mode and is awaiting a contactless transaction.

When a contactless transaction is started the first (left hand) status light will be lit steadily; this indicates that your terminal is in use but a card is not being read.

When a contactless card is presented to your terminal during a contactless transaction the second, third and fourth status lights will be lit in turn. The card read is successful when all four status lights are lit and the confirmation tone is heard.

Terminal Keypad

The Ingenico iCT200 key pad is laid out as below.

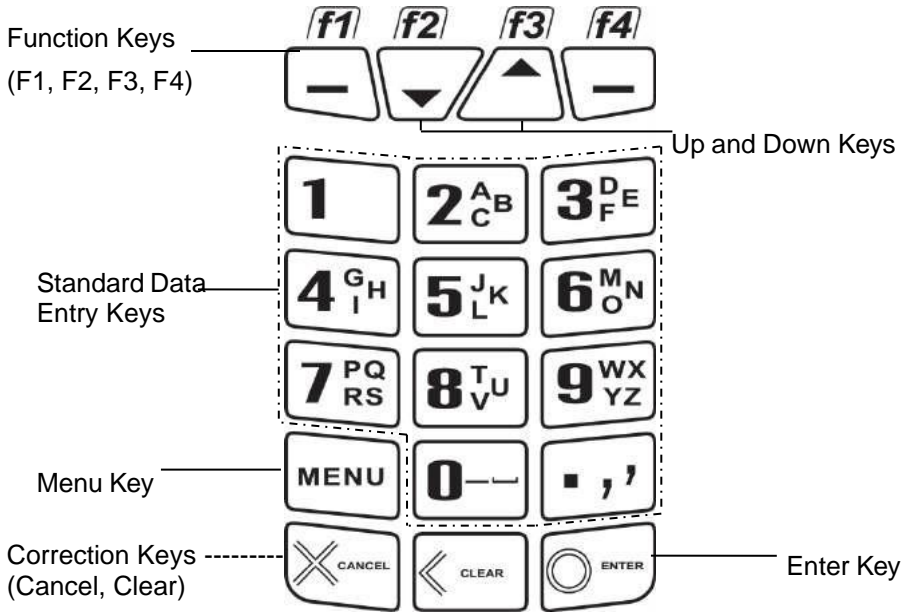

Function Keys

The four function keys allow you to choose options displayed on the screen, and in certain circumstances the middle two function keys can be used as Up and Down keys. The function keys therefore have icons printed on the keys and labels displayed above the keys (at the very bottom of the display).



For clarity the convention used in this User Guide is thus:

- F2 and down refer to the different uses of the same key;
- F3 and up refer to the different uses of the same key.

Entering and Correcting Data

To enter numbers press the relevant keys. If you make a mistake you can correct this using the correction keys. Press the clear key once to delete one character at a time. Press the cancel key once to delete the entire line; pressing the cancel key again will cancel the transaction.

When typing in an authorisation code, for example, you may need to enter letters as well as number. Where you see the  123 graphic on screen you can toggle the input mode by pressing F4. To enter uppercase letters use the ABC input mode, and to enter lowercase letters use the abc input mode.

When entering letters, you should press the number key repeatedly until the desired letter appears. If you want to type B then you must press 2, 2. To move on to next character either press another key, or wait for the flashing cursor to appear.

Terminal Display

The Ingenico iCT220 & iCT250 screen displays.

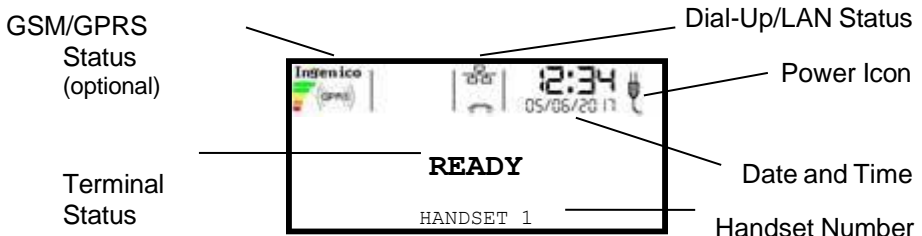

Fig1. Terminal Display iCT250

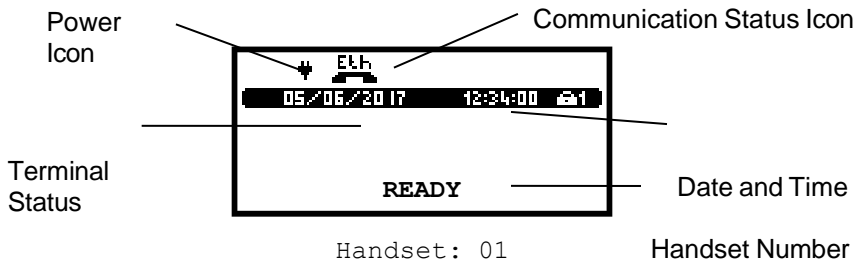

Fig2. Terminal Display iCT220





During normal operation the top row (showing the power status icon, and the communication status icon) is always displayed on the screen. Therefore all subsequent screen shots in this User Guide are shown without this top line.

When your terminal has been powered on and after a short initialisation process the terminal will display the terminal status of **READY**, this simply means that the terminal has initialised and is ready to use.

If your terminal displays the **NOT READY** status message then your terminal is not initialised. Press menu once, and choose the **SETUP** menu option. You should contact the terminal Helpdesk if the problem persists after a successful TMS Call.

Display Icons

You will see a variety of different icons and graphics on the screen of your terminal.

	<p>The plug symbol indicates that your terminal is connected to the power supply and is therefore powered on.</p>
	<p>The network symbol indicates whether your terminal is connected to a Local Area Network (LAN) via an Ethernet cable.</p> <ul style="list-style-type: none"> • White icon: not connected to LAN • Green icon: connected to LAN <p>This symbol may show green even if your terminal is communicating via a different method.</p>
<p><i>Eth & ETH</i></p>	<p>iCT220 models display the letters 'Eth' = connected and IP obtained or 'ETH' = cable connected but no IP obtained</p>
	<p>The phone symbol indicates whether your terminal is communicating via a dial-up connection. The possible dial-up communication methods for your terminal are PSTN or GSM.</p> <ul style="list-style-type: none"> • Grey icon (as shown): not connected • Yellow raised icon: connecting (PSTN only) • Green raised icon: connected
	<p>The group of icons on the far left of the screen indicate the status of the GSM/GPRS network.</p> <ul style="list-style-type: none"> • The coloured bars indicate the signal strength of the mobile network, with red being the weakest and green being the strongest. If the signal is weak communications to the acquirer may fail. • The network name is shown above the signal strength bars indicating the mobile network that the terminal is using. • The accompanying legend of GSM or GPRS within the wave symbol indicates the type of mobile communication being used. If this legend is in white then it is currently idle, whereas green indicates that the communications type is being used. A GPRS session may be maintained longer than one transaction making subsequent connections quicker, therefore the GPRS legend may remain green even though no transaction is taking place.
	<p>These labels shown on the screen indicate the choice that can be made by pressing the corresponding function key. This is seen in the standard menu screens and on choice screens</p>

Menu Screens

When you press the menu key from the idle screen your terminal will enter the application menus. All the menu screens have the same layout.

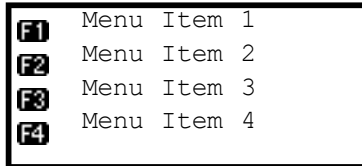

To choose Menu Item 1 you should press the F1 key, and so on.

When navigating around the menu structure: by pressing the menu key you will move to the next menu screen (if available); by pressing the cancel key you will move back to the last menu screen (if available), or return to the idle screen.

A schematic of the menu structure is found in the section entitled ***Menu Structure***.

When you are required to make a choice between two options the screen will display the title or question, followed by the choices. The choices are always chosen by pressing either the F1 or F4 keys, as appropriately marked by the **F1** or **F4** labels on the screen.

Paper Loading

Your terminal is supplied with one paper roll already installed. When the paper roll is nearing the end a red line will appear on the paper, this indicates that the paper roll must be replaced.

1. Hold your terminal securely in one hand, with the other hand, and by using two fingers, lift the printer cover release as shown. Fully open the printer cover and remove the old roll of paper.

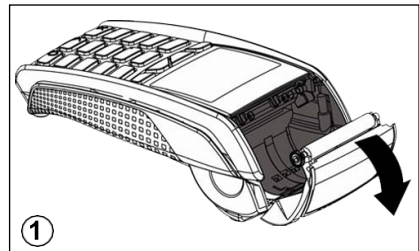
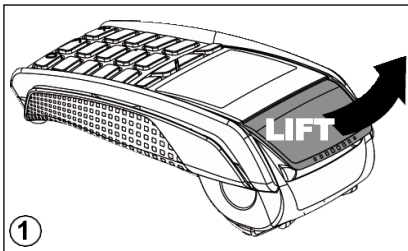

2. Unstick the end of the new roll, leaving the end free, hold the paper roll and carefully place into the printer compartment.

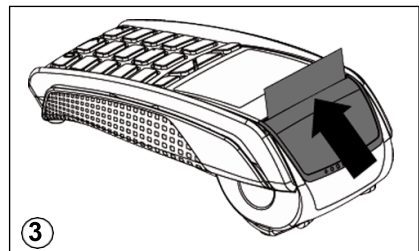
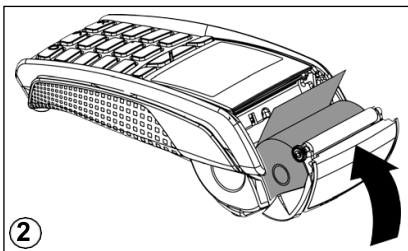

3. Holding the free end of the paper and your terminal, close the printer cover carefully and push firmly until it locks.
4. While your terminal is displaying the idle screen, press and hold the clear key to ensure that the paper feeds correctly.

Only thermal paper rolls that are 57mm wide and 40mm in diameter can be used in your terminal. Attempting to fit rolls of a different size may damage your terminal.

You should only use approved paper rolls as supplied by your terminal supplier. Details on how to contact us in order to order supplies of paper

rolls can be found on the contact sticker found on the underside of your terminal. If appropriate, you may also find these details on the inside cover of this User Guide.



**Only use approved paper rolls supplied by your terminal supplier.
Attempting to fit rolls of a different size may damage your terminal.
Only open the printer cover as shown, do not force the printer cover.**

Terminal Installation

You should set up the terminal in a convenient location close to a power source and an analogue telephone line.

Firstly identify all parts as shown in the image below.



1. Your terminal
2. "Magic Cable" (attached to terminal) with install kit (cable tie, and self-adhesive support)
3. Telephone Line Lead
4. BT Converter for Telephone Line Lead
5. UK Power Supply Unit

The terminal uses the "Magic Cable" Unit (2) to manage connections to the power and the telephone line. The unit has 4 sockets for connections: POWER (⏏), RS232 (not used), TEL (⏏ IN), and ETH.



Connect one end of the Telephone Line Lead (3) to the socket marked TEL IN on the "Magic Cable" Unit (2), and connect the second end to the socket on the BT Converter (4).



Lastly connect the UK Power Supply Unit (5) into the power socket on the "Magic Cable" Unit (2).

“Magic Cable” Installation

The “Magic Cable” will be supplied attached to your terminal. The Power Supply Unit should be plugged into both the “Magic Cable” unit and your mains power socket. The terminal will now power on.

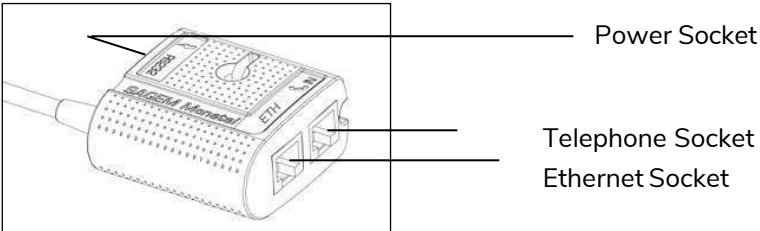

If not already attached, plug the Telephone Line Lead in to both the socket marked **IN** on the “Magic Cable” Unit, and your BT Telephone socket, via the BT Converter (supplied and attached).

The “Magic Cable” can be secured to the terminal’s work area in a number of ways so as to reduce stress on the terminal and cable’s connection.

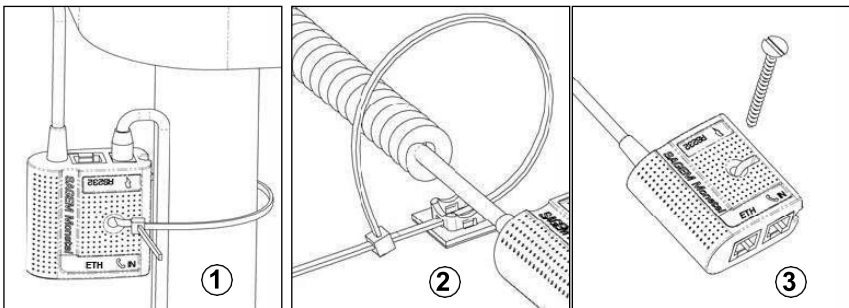

Examples of securing the “Magic Cable” are as illustrated:

1. Using the supplied cable tie to attach to a table leg (or similar).
2. Using the supplied cable tie and self-adhesive support.
3. Using a counter-sunk screw (not supplied) to an appropriate surface.

The “Magic Cable” should be readily accessible for support and terminal helpdesk diagnosis purposes.

SIM Card Installation (optional)

Your terminal may require a SIM Card in order to communicate via a mobile network.

In order to access the SIM Card you must first remove the SIM compartment cover. Using your thumb on the grip provided, push the cover away from the rest of the terminal to disengage the clips, before then lifting the cover away.

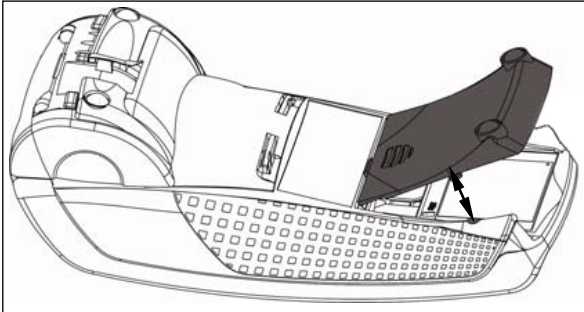

Insert the SIM Card into the slot marked GPRS. Take care to ensure that the SIM Card is inserted in the correct manner. The chip should be facing downwards and the cut out corner of the SIM Card is as shown.

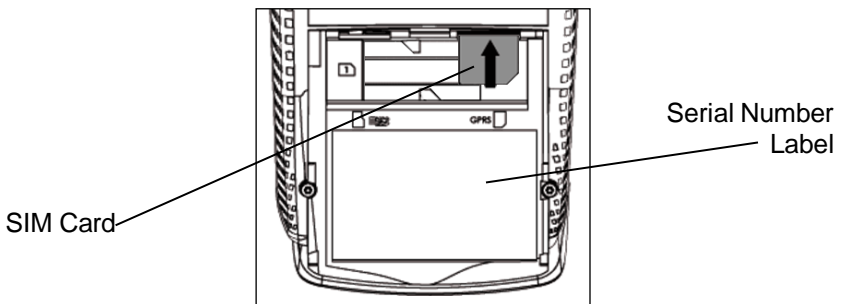

Do not use any tools when installing or removing your SIM Card.



**Only use the SIM Card supplied to you by your terminal supplier.
If your SIM Card is lost, stolen, or damaged you should contact the terminal Helpdesk immediately.**

Telephone Lines and Broadband

Your terminal can be used on a variety of telephone lines, however to use your terminal on some lines you may be required to change the telephone network (PSTN) setting in the terminal. Your terminal is pre-configured so that it may work on a direct telephone connection.

If your telephone line requires you to dial a 9 (for example) to get an outside line then you are on a telephone exchange or switchboard and will need to configure the 9 (for example) in the terminal so it is able to dial out of the telephone exchange.

To configure the PSTN prefix, press the menu key **twice**, and then choose `SUPERVISOR` by pressing the F3 key. You will be asked to type your current supervisor password, and confirm this by pressing the enter key, and choose `CONFIG` by pressing the F3 key, followed by `SET PSTN` by pressing the F3 key again. Type in the PSTN prefix (typically 9) followed by the enter key.

✓ **MENU, MENU, F3, [password], ENTER, F3, F3**

If your telephone line has Broadband (ADSL) active then you must use an ADSL micro-filter between your terminal's telephone line lead and your BT socket. For more information on this, and to purchase additional ADSL micro-filters you should contact your ADSL internet service provider.

If your telephone line is shared with other equipment, such as a telephone or fax machine, then you will not be able to use your terminal while using the telephone line with the other equipment. It is recommended that your terminal should be used on a dedicated telephone line.

If your telephone line has a voicemail/answering service or call waiting, it is recommended that these features are turned off. It is also strongly recommended that your terminal does not share with an alarm system (RedCare line). Your terminal may not function correctly, and it may invalidate your alarm/ insurance policy.

Inserting a Chip Card

Chip Cards should be inserted firmly into your terminal as illustrated with the chip facing up and into the card reader.

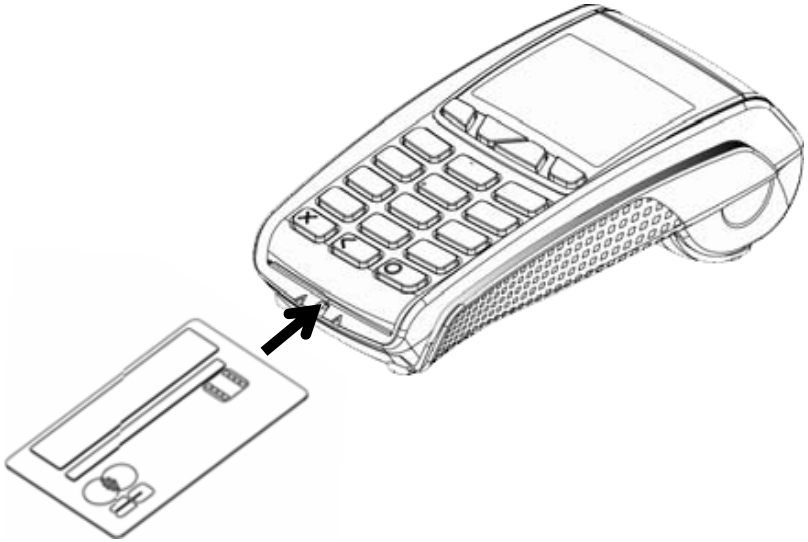

If you see the prompt `BAD READ`, check the orientation of the card and try again. If the card cannot be read on the third attempt, your terminal will prompt you to swipe the card.



The card MUST remain inserted until your terminal prompts you to remove the card. If the card is removed prematurely, the transaction will be cancelled.

Chip Cards can hold the details for more than one payment application (for example Mastercard and Maestro). If the `SELECT APPLICATION` screen is displayed after the card has been inserted, the cardholder should select the payment application that they wish to use for the transaction.



Press F1 for Mastercard or
Press F2 for Maestro.

Swiping a Card

With the magnetic stripe facing down and towards the screen as illustrated run the edge of the card along the bottom of the card swipe slot on the right of your terminal. You should swipe the card in one continuous movement and at an even speed.

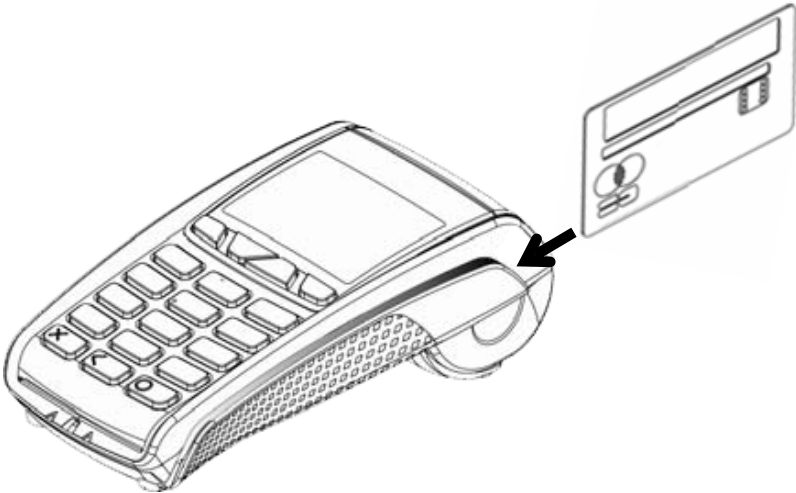

If you see the prompt `BAD SWIPE`, check the orientation of the card and try again. If the card cannot be read on the third attempt, your terminal will prompt you for manual key entry of the card number.

If a Chip Card is swiped, your terminal will request that you insert the same card into the Chip card reader.

USE CHIP READER

Presenting a Contactless Card

A contactless card should be presented by the cardholder only when prompted to do so on the screen and the first status light is lit steadily.

The card should be presented towards the contactless logo shown on the screen - at the centre of the contactless card read zone.



When a contactless card is presented to your terminal during a contactless transaction the second, third and fourth status lights will be lit in turn.

The card read is successful when all four status lights are lit and the confirmation tone is heard. If the card is removed prior to this the card read will be unsuccessful and the cardholder will be prompted to re- present the card. A card read should take between 1 and 2 seconds.

3. Transactions

Performing Transactions

In order to perform a transaction in a quick and efficient manner you may type in the transaction amount from the idle screen. This method may be used to start any sale transaction, regardless of card type is (i.e. contactless cards or cards with, or without, a chip).

Enter the transaction amount while the idle screen is being displayed by typing in the amount in pence (i.e. 1234 for £12.34) followed by the enter key. If you make a mistake when entering the amount you can correct this by using the correction keys. Press the clear key once to delete one character at a time. Press the cancel key to cancel the amount entry and return to the idle screen.

Contactless transactions are performed by this method and when the transaction value is under the contactless limit (e.g. £30.00). Your terminal will only prompt for a card to be presented when a contactless transaction is allowed. When a contactless transaction is allowed your terminal will show a contactless symbol on the screen.



If you consistently sell an item at the same price you can 'recall' the last transaction amount by pressing the dot key while the idle screen is being displayed. Your terminal will allow you to confirm if this is the correct amount, and you can continue with the transaction by pressing the enter key.

Alternatively the traditional method of starting the transaction by swiping or inserting the card first may be utilised if required.

Printing the Customer Copy (Duplicate)

Only the merchant copy is printed during a contactless transaction. Because the transaction value is low and fast transaction times are desired, the customer copy is not printed by default. Contact terminal helpdesk if customer contactless receipts are required by default.

If the customer requires a receipt then a customer copy may be printed

any time until another transaction is performed by pressing the F1 key whilst the idle screen is displayed. This prints a duplicate of the last transaction taken and is not restricted to contactless transactions.



For security reasons the full card number is not shown on the customer copy.

Contactless High Value Payment (HVP) – Wallet Payments

High Value Payments are contactless payments that are above the limit for contactless cards (e.g. £30.00) but are protected by the cardholder verifying themselves to the mobile phone either by the use of a scanned thumb/fingerprint in the case of Apple Pay, or by the entry of a pass code for other mobile phone manufacturers. This process is known as a Cardholder Device Cardholder Verification Method or CDCVM for short.

This means that once HVP is enabled, the contactless logo will be displayed on your terminal for all transactions rather than just those under the contactless card limit (e.g. £30.00).

Acceptance of normal contactless cards for transactions below the £30 limit will continue as normal and, if a cardholder taps a contactless card for a transaction above the £30 limit, the terminal will instruct them to complete the transaction using chip and PIN.

In some cases, a cardholder may need to tap their mobile phone against the contactless reader twice. This is because they have not pre entered their CDCVM on their device prior to starting the transaction and their device has prompted them to complete their CDCVM and tap the phone again. The cardholder should follow the instructions on their device to complete the transaction.

Sales - Inserted Cards (Method One)

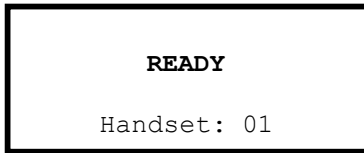

The idle screen will be displayed on the terminal.

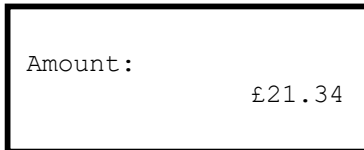

Enter the sale amount in pence (e.g. 2134 for £21.34) and press the enter key.

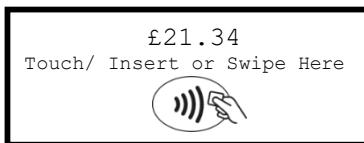

Confirm the sale amount is correct and insert the card into the card reader.

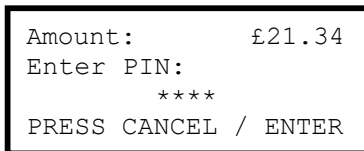

If a PIN is requested, the Customer must enter their PIN code followed by the enter key.

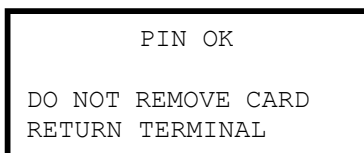

After the customer has entered their PIN they will be prompted to return the terminal to you.

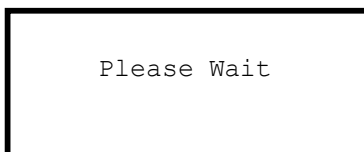

The terminal will dial out to the acquirer for authorisation.

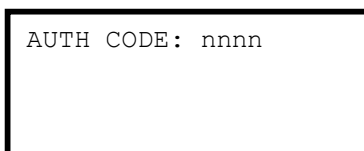

If the transaction has been authorised then an auth code will be displayed.



The terminal will print the merchant copy for you to retain. If a signature is needed the customer must sign.

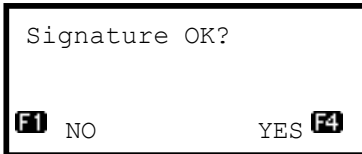

If required check the signature:
Press F1 for an invalid signature
or Press F4 for a valid signature.



The terminal will print the customer copy to give to the customer for them to retain.

The terminal will return to the idle screen.



NEVER ask the customer to divulge their PIN Code. Customers should be advised to ensure that they are not being overlooked when entering their PIN Code.



DO NOT remove the card until the terminal has prompted you to do so.



You MUST retain the merchant copy for your records. If a signature is required then this copy must be signed by the customer.

Sales - Inserted Cards (Method Two)

READY
Handset: 01

From the idle screen, insert the card into the card reader.

Enter Sale
£0.00

Enter the sale amount in pence (e.g. 1234 for £12.34) and press the enter key.

Amount: £12.34
Enter PIN:

PRESS CANCEL / ENTER

If a PIN is requested, the Customer must enter their PIN code followed by the enter key.

PIN OK
DO NOT REMOVE CARD
RETURN TERMINAL

After the customer has entered their PIN they will be prompted to return the terminal to you.

Please Wait

The terminal will dial out to the acquirer for authorisation.

AUTH CODE: nnnn

If the transaction has been authorised then an auth code will be displayed.

Printing

The terminal will print the merchant copy for you to retain. If a signature is needed the customer must sign.

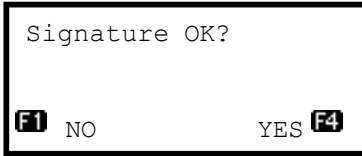



If required check the signature:
Press F1 for an invalid signature
or Press F4 for a valid signature.



The terminal will print the customer
copy to give to the customer for them
to retain.

The terminal will return to the idle screen.

-  **NEVER ask the customer to divulge their PIN Code. Customers should be advised to ensure that they are not being overlooked when entering their PIN Code.**
-  **DO NOT remove the card until the terminal has prompted you to do so.**
-  **You MUST retain the merchant copy for your records. If a signature is required then this copy must be signed by the customer.**

Sales - Contactless Cards

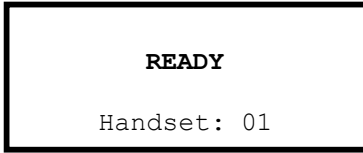

The idle screen will be displayed on the terminal.

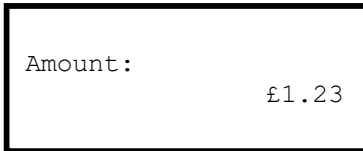

Enter the sale amount in pence (e.g. 123 for £1.23) and press the enter key.

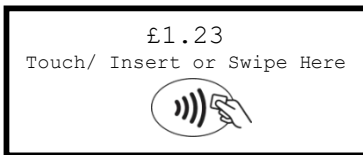

Confirm the sale amount is correct and invite the cardholder to present their card to the screen. The first status light will be lit steadily.

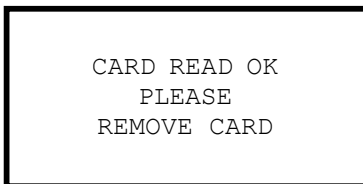

During the card read the second, third and fourth status lights will be lit steadily in turn. A confirmation tone and message will be displayed. The card can be removed from the card read zone.



The terminal will dial out to the acquirer (if required) and authorise the transaction.



The terminal will show the transaction result, and will print the merchant copy for you to retain.

The terminal will return to the idle screen.



The customer **MUST NOT** remove the card until the terminal has prompted them to do so, sounded the confirmation tone, and all status lights lit steadily.



You **MUST** retain the merchant copy for your records. If a signature is required then this copy must be signed by the customer.

Dealing with Contactless Card Read Failures

A contactless card read may fail, and the customer will be prompted to re-present their card.

If the card is removed too soon - before all four contactless status lights are lit; before the confirmation tone is heard; or before prompted to remove the card - the card read will fail.



If the card is removed too soon the card read will fail. An alert tone will sound and the customer will be prompted to re-present the card.

If more than one contactless card is presented to the contactless card read zone together then the card read will fail. This may occur if the card is presented in a wallet with other contactless payment cards, or other contactless cards such as public transport smart cards.

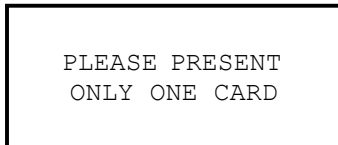

If more than one card is presented the card read will fail. An alert tone will sound and the customer will be prompted to re-present the card.

In both cases the terminal will continue as per a normal contactless sale, refer to the instructions for *Sales – Contactless Cards* to complete the transaction.

Dealing with Fallback Requests

Occasionally a contactless card will require a further security check - this is a routine operation. In this case your terminal will prompt you that the transaction must be completed with cardholder verification (PIN entry or Signature as appropriate).

**INSERT OR
SWIPE CARD**

If the card requires a further security check an alert tone will sound and you will be prompted to continue the transaction as if the card is not contactless enabled.

Sales - Swiped Cards

READY
 Handset: 01

From the idle screen, swipe the card through the card swipe.

Enter Sale
 £0.00

Enter the sale amount in pence (e.g. 1234 for £12.34) and press the enter key.

Please Wait

The terminal will dial out to the acquirer for authorisation.

AUTH CODE: nnnn

If the transaction has been authorised then an auth code will be displayed.

Printing

The terminal will print the merchant copy for you to retain. The customer must sign this copy.

Signature OK?
 NO YES

Check the signature:
 Press F1 for an invalid signature or
 Press F4 for a valid signature.

Printing

The terminal will print the customer copy to give to the customer for them to retain.

The terminal will return to the idle screen.

Sales with Gratuity (Tip Mode)



You must ensure that this option is enabled on your acquirers Merchant Account. Contact your acquirer to ensure that this option is available to you.

Your terminal is not pre-configured to allow for Gratuities (i.e. tips). If you would like the Gratuity mode enabled on your terminal please contact the terminal Helpdesk.

Gratuity mode would commonly be used within the leisure industry in order to allow the customer to add a tip to the final amount before completing the transaction. For sales with inserted cards, when Gratuity mode is enabled, your terminal will prompt for the customer to enter a gratuity on the screen.

Alternatively your terminal can be configured to print an additional ticket for the customer to fill in with any gratuity and the final transaction amount. If you wish your terminal to be configured in this way please contact the terminal Helpdesk.

For sales with swiped cards when Gratuity mode is enabled in this manner, the merchant copy will allow the customer to fill in with any gratuity and the final transaction amount. This is unaffected by the method of entering the gratuity for inserted cards.

If you wish, your terminal can be configured to allow the entry via the choosing of set monetary values, set percentages or a combination of the two; contact the helpdesk if you wish to enable tips in this manner

When Gratuity mode is enabled, your terminal will only contact the acquirer for authorisation after the final transaction amount (including any gratuities) is known. For swiped cards this means that this is after the terminal has printed the merchant copy for signature.

Due to the authorisation code being gained after the merchant copy is printed, the authorisation code will not be shown. The authorisation codes are printed on the transaction breakdown on the X and Z Balance reports.

If you wish, your terminal can be configured to print an additional receipt at the end of the transaction which shows the authorisation code and the gratuity entered. If you wish your terminal to be configured in this way please contact the terminal Helpdesk.

Sales with Gratuity - Inserted Cards (On Ticket Method)

READY
Handset: 01

From the idle screen, insert the card into the card reader.

Enter Sale
£0.00

Enter the sale amount in pence (eg. 1234 for £12.34) and press the enter key.

Printing

The terminal will print the Final Amount copy, which you should give to the customer to fill out.

Enter Final Amount:
£0.00
 NO TIP

Enter the final amount of the sale in pence (e.g. 1334 for £12.34 + £1.00 tip) and press the enter key.

Amount: £13.34
Enter PIN:

PRESS CANCEL / ENTER

The final amount will be shown, the Customer must enter their PIN code followed by the enter key.

PIN OK
DO NOT REMOVE CARD
RETURN TERMINAL

After the customer has entered their PIN they will be prompted to return the terminal to you.

Please Wait



The terminal will dial out to the acquirer for authorisation.

AUTH CODE: nnnn

If the transaction has been authorised then an auth code will be displayed.

Printing

The terminal will print the merchant copy for you to retain. If a signature is needed the customer must sign.

Signature OK?
 NO YES 

If required check the signature:
Press F1 for an invalid signature
or Press F4 for a valid signature.

Printing

The terminal will print the customer copy to give to the customer for them to retain.

The terminal will return to the idle screen.



NEVER ask the customer to divulge their PIN Code. Customers should be advised to ensure that they are not being overlooked when entering their PIN Code.



DO NOT remove the card until the terminal has prompted you to do so.



You MUST retain the merchant copy for your records. If a signature is required then this copy must be signed by the customer.

Sales with Gratuity - Inserted Cards (On Screen Method)

READY

Handset: 01

From the idle screen, insert the card into the card reader.

Enter Sale

£0.00

Enter the sale amount in pence (e.g. 1234 for £12.34) and press the enter key.

Amount: £12.34
Add Gratuity?

F1 NO YES **F4**

The customer must confirm if a gratuity is to be added.

Amount: £12.34
Gratuity: £0.00

F1 NO TIP

If a gratuity is to be added, they must enter amount of the tip in pence (e.g. 100 for £1.00) and enter.

Amount: £13.34
Enter PIN:

PRESS CANCEL / ENTER

The final amount will be shown, the Customer must enter their PIN code followed by the enter key.

PIN OK

DO NOT REMOVE CARD
RETURN TERMINAL

After the customer has entered their PIN they will be prompted to return the terminal to you.

Please Wait

The terminal will dial out to the acquirer for authorisation.

AUTH CODE: nnnn

If the transaction has been authorised then an auth code will be displayed.

Printing

The terminal will print the merchant copy for you to retain. If a signature is needed the customer must sign.

Signature OK?
F1 NO YES F4

If required check the signature:
Press F1 for an invalid signature
or Press F4 for a valid signature.

Printing

The terminal will print the customer copy to give to the customer for them to retain.

The terminal will return to the idle screen.



NEVER ask the customer to divulge their PIN Code. Customers should be advised to ensure that they are not being overlooked when entering their PIN Code.



DO NOT remove the card until the terminal has prompted you to do so.



You MUST retain the merchant copy for your records. If a signature is required then this copy must be signed by the customer.

Sales with Gratuity - Swiped Cards

READY

Handset: 01

From the idle screen, swipe the card through the card swipe.

Enter Sale

£0.00

Enter the sale amount in pence (e.g. 1234 for £12.34) and press the enter key.

Printing

The terminal will print the Merchant copy, which you should give to the customer to fill out.

Signature OK?

F1 NO YES **F4**

Check the signature:
Press F1 for an invalid signature or
Press F4 for a valid signature.

Enter Final Amount:

£0.00

F1 NO TIP

Enter the final amount of the sale in pence (e.g. 1334 for £12.34 + £1.00 tip) and press the enter key.

Please Wait

The terminal will dial out to the acquirer for authorisation.

AUTH CODE: nnnn

If the transaction has been authorised then an auth code will be displayed.

The terminal will print the customer copy to give to the customer for them to retain, and will return to the idle screen.

Sales with Cashback



You must ensure that this option is enabled on your acquirers Merchant Account. Contact your acquirer to ensure that this option is available to you; this option may not be available for all account types.

Your terminal is not pre-configured to allow for Sales with Cashback. If you would like Cashback mode enabled on your terminal please contact the terminal Helpdesk.

READY

Handset: 01

From the idle screen, insert or swipe the customer's card.

Enter Sale

Enter the sale amount in pence (e.g.1234 for £12.34) and press the enter key.

Cashback?

NO

F1

If cashback is allowed for the customer's card the terminal will display a cashback prompt:
Press F1 for No; or Press F4 for Yes.



Enter Cashback

£0.00

Enter the cashback amount in pence and press the enter key.

If cashback is not required press the enter key without entering an amount.

The terminal will continue as per a normal sale, refer to the instructions for a Sale Transaction to complete the transaction.



Cashback is only available on Debit Cards, and normally has a limit of £50.00.

Split Bills

Your terminal is not pre-configured to allow for Split Bills. If you would like the Split Bill functionality enabled on your terminal please contact the terminal Helpdesk.

The Split Bill functionality would commonly be used within the leisure industry in order to break down a bill associated with a table into amounts that can be paid by each person using differing payment methods.

The options available for Split Bills are:

PER PERSON	Allows the bill to be split equally between multiple customers.
PER COUPLE	Allows the bill to be split equally between multiple customers, but allows for one person to pay per couple.
VARIABLE SPLIT	Allows the bill to be split unequally between multiple customers.

Surcharging

Your terminal is not pre-configured to allow for Surcharging. If you would like the Surcharge functionality enabled on your terminal please contact the terminal Helpdesk.

The Surcharge functionality would commonly be used within the leisure & service industries in order to add a surcharge of a set amount or set percentage rate to the total of the bill automatically. For example you could automatically apply a surcharge of 10% to all transactions over £10.00, and a £1.00 surcharge to all transactions of £10.00 and less.

You can discuss your specific requirements by contacting the terminal Helpdesk.

Refunds

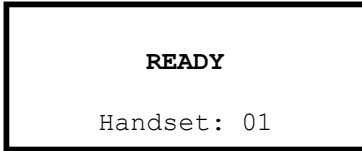

From the idle screen, press the menu key once.

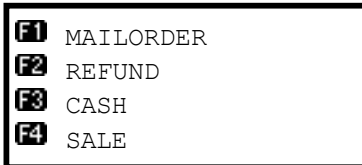

Select the menu option REFUND by pressing the F2 key.

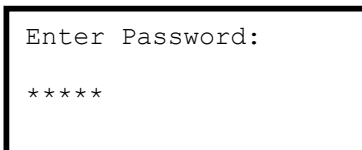

Enter the supervisor password followed by enter.

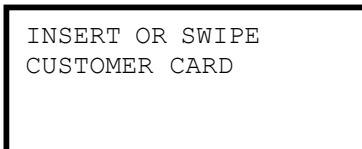

Insert or swipe the customer's card.

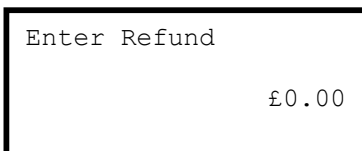

Enter the refund amount in pence (e.g. 1234 for £12.34) and press the enter key.

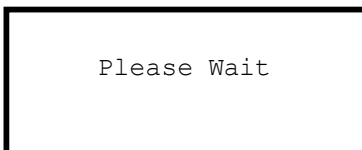

The terminal will dial out to the acquirer for authorisation.

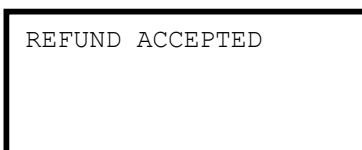

If the transaction has been authorised then REFUND ACCEPTED will be displayed.



The terminal will print the merchant copy for you to retain. If a signature is needed the customer must sign.

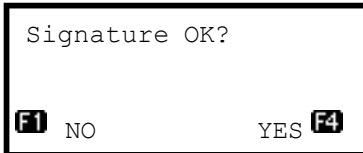

Check the signature:
Press F1 for an invalid signature or
Press F4 for a valid signature.



The terminal will print the customer copy to give to the customer for them to retain.

The terminal will return to the idle screen.



DO NOT remove the card until the terminal has prompted you to do so.



You MUST retain the merchant copy for your records. This copy must be signed by the customer.



If your terminal has Gratuity/Tip mode enabled then the signature check will be done BEFORE the terminal dials the acquirer for authorisation.

Mailorder Transactions (Customer Not Present)



You must ensure that this option is enabled on your acquirers Merchant Account.

Your terminal is pre-configured for Mailorder (Customer Not Present) transactions.

Mailorder transactions are performed without the customer or the card being present. All card details must be manually entered so please take note of what information will be asked for by your terminal.

If supported by your acquirer and by the card type taken, you will have the option of entering the CSC (Card Security Code) and using the AVS (Address Verification Service).

The CSC is the last three digits of the number printed on the signature strip on the back of the card.



American Express cards have a four digit Card Security Code printed on the front of the card, any numbers on the signature strip should be ignored.

To use AVS checking, you will be prompted to input the numerical digits only from the customer's postcode and address. The response from the acquirer will then give you the result of the security checks to help you decide if you wish to continue with the transaction.

Mailorder - CSC/AVS Results

Please be aware that the CSC/AVS result is intended only to guide you in a decision to void or confirm an already authorised transaction. Contact your acquirer for more information and details of liability.

DATA MATCHED	Both the CSC and AVS data matches.
AVS MATCH ONLY	Only the AVS data matches.
CSC MATCH ONLY	Only the CSC data matches.
DATA NON MATCH	Neither the CSC nor AVS data matches.
NOT CHECKED	The data was not checked.

The data may not be checked if the service is not supported or if there is a temporary system failure.

Mailorder - Sales & Refunds

READY

Handset: 01

From the idle screen, press the menu key once.

F1 MAILORDER
F2 REFUND
F3 CASH
F4 SALE

Select the menu option MAILORDER by pressing the F1 key.

MAILORDER

F1 REFUND SALE **F4**

Choose the required transaction:
Press F1 for REFUND or Press F4
for SALE.

MAILORDER SALE
Key Card No:

Key in the customer's card number and press the enter key.

Expires (MMYY)

If you see this prompt enter the card expiry date as MMY and press the enter key.

Start Date (MMYY)

If you see this prompt enter the card start date as MMY and press the enter key.

Issue Number:

If you see this prompt enter the card issue number and press the enter key.

Enter CSC:

If you see this prompt enter the 3 or 4 digit Card Security Code (CSC) and press the enter key.

Postcode Nums:

If you see this prompt enter the postcode numbers (e.g. 27 for GU2 7YB) and press the enter key.

Address Nums:

If you see this prompt enter the address numbers (e.g. 3000 for 3000 Cathedral Hill) and press the enter key.

Enter Sale
£0.00

Enter the sale amount in pence (e.g. 1234 for £12.34) and press the enter key.

Please Wait

The terminal will dial out to the acquirer for authorisation.

AUTH CODE: nnnn
DATA MATCHED
F1 VOID CONFIRM F4

If the transaction has been authorised then an auth code will be displayed, together with the CSC/AVS check result. You must decide whether to continue with the transaction:

Press F1 to VOID the transaction or Press F4 to CONFIRM and continue with the transaction.

Printing

The terminal will print the merchant copy for you to retain.

TEAR OFF TICKET
AND RETAIN (ENTER)

Tear off the merchant copy and press the enter key.

Printing

The terminal will print the customer copy to give to the customer for them to retain.

The terminal will return to the idle screen.



The card Issue Number must be entered in the correct format; if the number is printed as 01 on the card then it must be entered as 01 and not as 1.



CSC and AVS checks are not mandatory for some acquirers, therefore if you do not wish to enter a value for, or do not know, the CSC or for the Postcode Numbers or Address Numbers, then you can press the enter key without entering a value.



If the address does not have any numbers, i.e. they have only a house name, then you should press the enter key without entering a value.



If the address contains a flat number and a house number, i.e. Flat 3, 45 Acacia Avenue you should enter all the numbers in order. In this example you would type 345 followed by the enter Key.

Account Verification



You must ensure that this option is enabled on your acquirer's Merchant Account. Contact your acquirer to ensure that this option is available to you.

In order to check that a customer's card is valid an Account Verification can be performed. Typically this would be used before opening a bar tab, or any situation where a low value Pre-Authisation would otherwise be performed. An Account Verification has **no value** and therefore does not affect the available balance on the customer's bank account.

To perform an Account Verification press the menu key **three times**, then choose ACC VERIFY by pressing the F3 key.

❖ MENU, MENU, MENU, F3

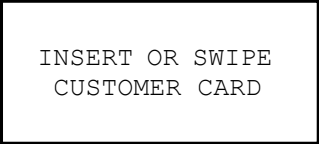

INSERT OR SWIPE
CUSTOMER CARD

Insert, swipe or key the customer's card.

The terminal will continue as per a normal sale with the exception that an amount is not prompted for, refer to the instructions for the appropriate sale transaction type to complete the transaction.

When an Account Verification is successful then ACCOUNT VERIFIED will be displayed on the terminal and printed on the transaction receipts.

Account Verification receipts carry the extra text of ACCOUNT VERIFICATION to indicate that the transaction details are not captured by the acquirer.



Account Verification may not be available on all card types.



If the ACC VERIFY option is not shown in the menu on your terminal then the Account Verification functionality is not available to you.

Hotel Mode



You must ensure that this option is enabled on your acquirers Merchant Account. Contact your acquirer to ensure that this option is available to you.

When a large value transaction is expected (typically in Hotel or Rental environments), a Pre-Authorisation can be made for the expected value, to check the customer's card is valid and the customer has enough credit available for the transaction.

If the expected value increases, then further Pre-Authorisations can be made. The final amount is fully authorised and captured by using the Completion function.

To perform a Hotel Mode transaction press the menu key **three times**, then choose HOTEL by pressing the F1 key.

✓ MENU, MENU, MENU, F1

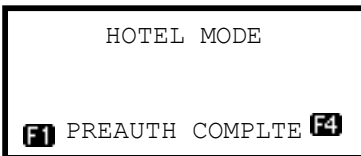

Choose the required transaction: Press F1 for PREAUTH or Press F4 for COMPLTE.

A Pre-Authorisation (PREAUTH) transaction proceeds as for a Sale transaction. If the customer's card number is keyed in, then you will be asked to confirm if the customer is present. The transaction details are not captured, so the customer's bank account is **NOT** debited, although the **available credit** on the customer's bank account will be reduced by the amount authorised. These transactions do not include gratuities.



Authorisation codes expire after 7 days (or 3-4 days for Maestro cards). If the transaction is not submitted within that time the customer's available balance will be restored by the authorised amount.

A Completion (COMPLTE) transaction requires the most recent authorisation code and the total amount of all pre-auths, in addition to the final amount to be debited from the customer's card. This transaction **will** require a signature check and **will** capture the transaction details.

Reversals

If a mistake in a transaction is identified immediately after the transaction has been completed, then the transaction can be completely reversed by selecting the REVERSAL function within 30 seconds of the completion of the transaction.

This function is particularly useful when the wrong transaction amount has been entered, and the mistake is only noticed on the customer copy.

To perform a reversal press the menu key **twice**, then choose REVERSAL by pressing the F4 key.

✓ **MENU, MENU, F4**

If the 30 second timer has not expired then your terminal will perform the reversal, contacting the acquirer if necessary.

When a reversal has been successfully performed the original transaction and the reversal **will not** appear on the customer's bank statement.

The original transaction and the reversal **will** appear on your Banking and X/Z Balance reports. Reversals are recorded as the opposite of the original transaction; if you reverse a Sale then the reversal will be shown as a Refund.

Duplicate Receipts

Your terminal can produce a duplicate copy of the customer receipt for the last completed transaction.

To print a duplicate ticket press the menu key **three times**, then choose DUPLICATE by pressing the F4 key.

✓ **MENU, MENU, MENU, F4**

All duplicate copies will have the word DUPLICATE printed at the top of the receipt.



Alternatively you can print a duplicate customer copy receipt when your terminal is displaying the idle screen by pressing the F1 key.

Cash Advance



You must ensure that this option is enabled on your acquirers Merchant Account. Contact your acquirer to ensure that this option is available to you; this option may not be available for all account types.

Your terminal is not pre-configured to allow for Cash Advance. If you would like Cash Advance mode enabled on your terminal please contact the terminal Helpdesk.

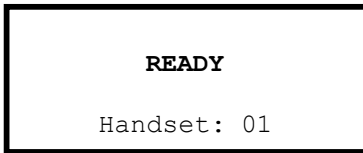

From the idle screen, press the menu key once.

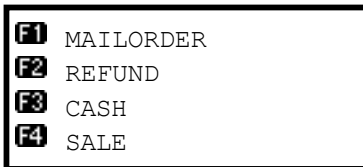

Select the menu option CASH by pressing the F3 key.

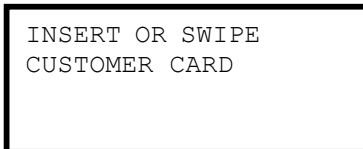

Insert or swipe the customer's card.

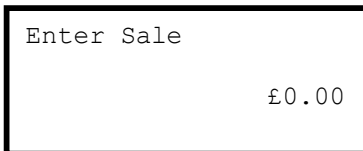

Enter the amount in pence (eg. 1234 for £12.34) for the transaction and press the enter key.

The terminal will continue as per a normal sale, refer to the instructions for a Sale Transaction to complete the transaction.

Balance Enquiry

Your terminal is not pre-configured to allow for Balance Enquiry. If you would like Balance Enquiry mode enabled on your terminal please contact the terminal Helpdesk.

Authorisation Only



You must ensure that this option is enabled on your acquirers Merchant Account. Contact your acquirer to ensure that this option is available to you.

An Authorisation Only transaction gives an authorisation code for a specific amount against a customer's card **without** the capture of the transaction details by the acquirer.

This facility is intended for merchants who wish to bank transactions using a different system, or to check that a customer's card is valid and/or the customer has enough credit for a transaction.

The transaction does **NOT** debit the customers bank account or credit your merchant account. The transaction value is **NOT** added to the terminal totals. When an Authorisation Only transaction is done the **available credit** on the customers bank account will be reduced by the amount authorised.

Authorisation Only transactions may be submitted to the acquirer through the Forced Transaction function. These transactions do not include gratuities.

To perform an Authorisation Only transaction press the menu key **twice**, then choose AUTH by pressing the F2 key.

✓ **MENU, MENU, F2**

F1	REFUND
F2	CHEQUE
F3	CASH
F4	SALE

Select the desired transaction type and perform the transaction as normal.



Authorisation Only receipts carry the extra text AUTHORISATION ONLY to indicate that the transaction details are not captured by the acquirer.



Authorisation codes expire after 7 days (or 3-4 days for Maestro cards). If the transaction is not submitted within that time the customers available balance will be restored by the authorised amount.

Forced Transactions

The Forced Transaction function allows for the completion of a transaction following a referral or voice authorisation. It also provides the opportunity to capture the details of transactions authorised by means other than your terminal. For example, card transactions authorised using paper vouchers and calls to the authorisation centre during a power cut, or transactions previously authorised using the Authorisation Only function.

You **must** have a valid authorisation code before performing a Forced Transaction.

To perform a forced transaction press the menu key **three times**, then choose **FORCE TRANS** by pressing the F2 key. You will be asked to type your supervisor password, then press enter.

- ✓ **MENU, MENU, MENU, F2, [password], ENTER**

F1	HOTEL
F2	FORCE TRANS
F4	DUBPLICATE

Select the desired transaction type.

F1	MAILORDER
F2	REFUND
F3	CASH
F4	SALE

Select the desired transaction type.

INSERT OR SWIPE CUSTOMER CARD

Insert, swipe or key the customer's card.

Enter Auth Code
— F4 123

Enter the authorisation code for the transaction and press the enter key.

The terminal will continue as normal, refer to the instructions for transaction type that you chose to complete the transaction.

Declined Transactions

The acquirer or the customer's card issuer can decline to authorise any transaction.

A declined response from the acquirer's host system will display a message on your terminal in place of the usual AUTH CODE: nnnn message. This can be, for example, DECLINED, NOT AUTHORISED, or RETAIN CARD. This message will be displayed on the screen for 60 seconds, or until the enter key is pressed.

A declined receipt will be printed which clearly indicates that the transaction has not been authorised. It will also show the message from the acquirer.

Transactions with an inserted Chip card may be declined by the card without the terminal contacting the acquirer's host system. You should advise the customer to contact their card issuer and request another means of payment.

If your terminal is unable to contact the acquirer for a transaction with an inserted Chip card, the transaction may be declined by the card with the message COMMS FAILURE DECLINED.



If the COMMS FAILURE DECLINED message is displayed there may be a problem with your telephone/network connection. This will be indicated by the diagnostic (DIAG) codes printed on the receipt. Refer to the section entitled *Diagnostic Codes* for more details.



If you are prompted to retain the customer card you should follow the standard procedures as laid down by your acquirer. There may be a cash reward from the card issuer for retaining a card after such prompt.

Referrals

A transaction may be referred for voice authorisation if an extra security check is required by the acquirer. The terminal will display or print instructions to call the acquirer. If a telephone number is not shown please use the standard voice authorisation number as supplied by that acquirer.

Once you have dialled or made a note of the telephone number press the enter key to continue.

Please be ready to quote your merchant number, the full card number and any referral message that was displayed (such as REFERRAL B or CODE 10 REFER). The authorisation centre may need to speak to the customer.



If requested to do so by the authorisation centre operator, you may remove the card from your terminal after a referral request in order to do further visual checks on the card.

At all other times, you should only remove the card when prompted to do so by your terminal.



If you are unable to answer a question from the authorisation centre operator, they will move on to the next security question.

If the transaction is authorised by the authorisation centre, your terminal will prompt you to enter both your supervisor password and the authorisation code. You should take care entering the authorisation code to avoid unnecessary chargebacks from your acquirer.

Your terminal will also refer transactions if it is unable to contact the acquirer. This can happen during exceptionally busy periods when the acquirer's host system cannot answer the authorisation request.



If you experience a high volume of referrals there may be a problem with your telephone/network connection. This will be indicated by the diagnostic (DIAG) codes printed on the receipt. Refer to the section entitled *Diagnostic Codes* for more details.



FRAUD ALERT: If you receive a telephone call asking you to use a temporary authorisation centre telephone number for all card transactions. It is imperative that you contact your acquirer to confirm the validity of the request BEFORE the temporary number is used.

4. Transaction Receipts

Merchant Copy - Signature Transactions

Swiped Cards with Signature (Merchant Copy)

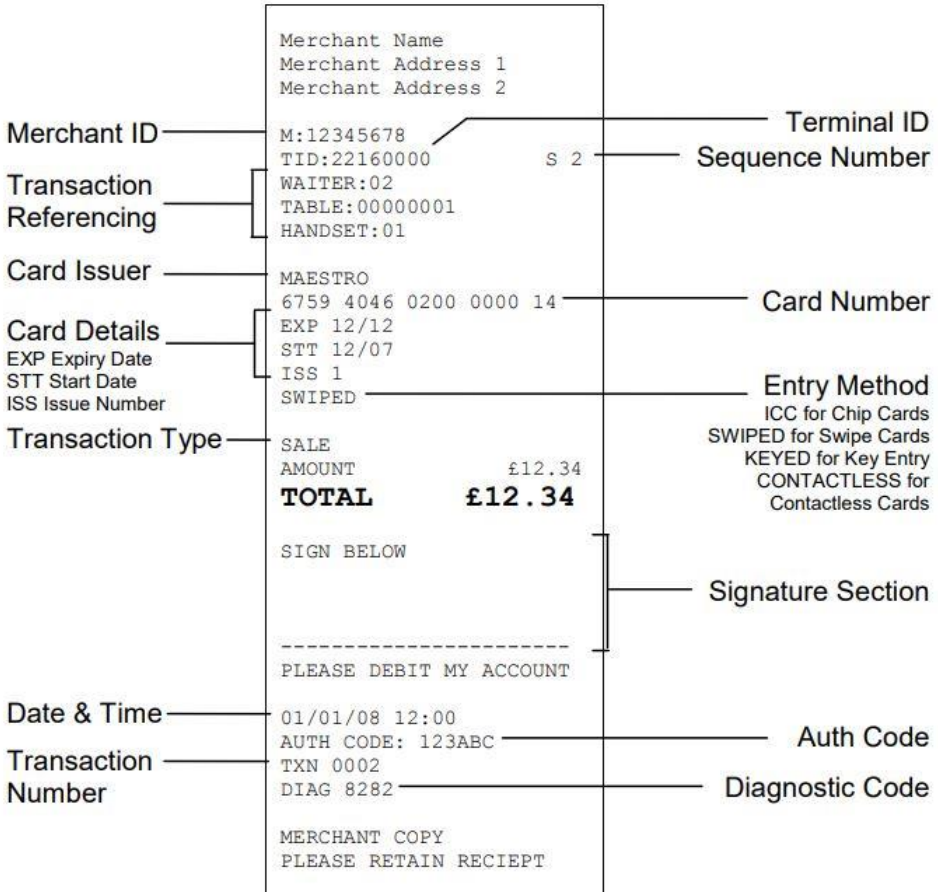

Swiped Cards with Signature and Gratuity (Merchant Copy)

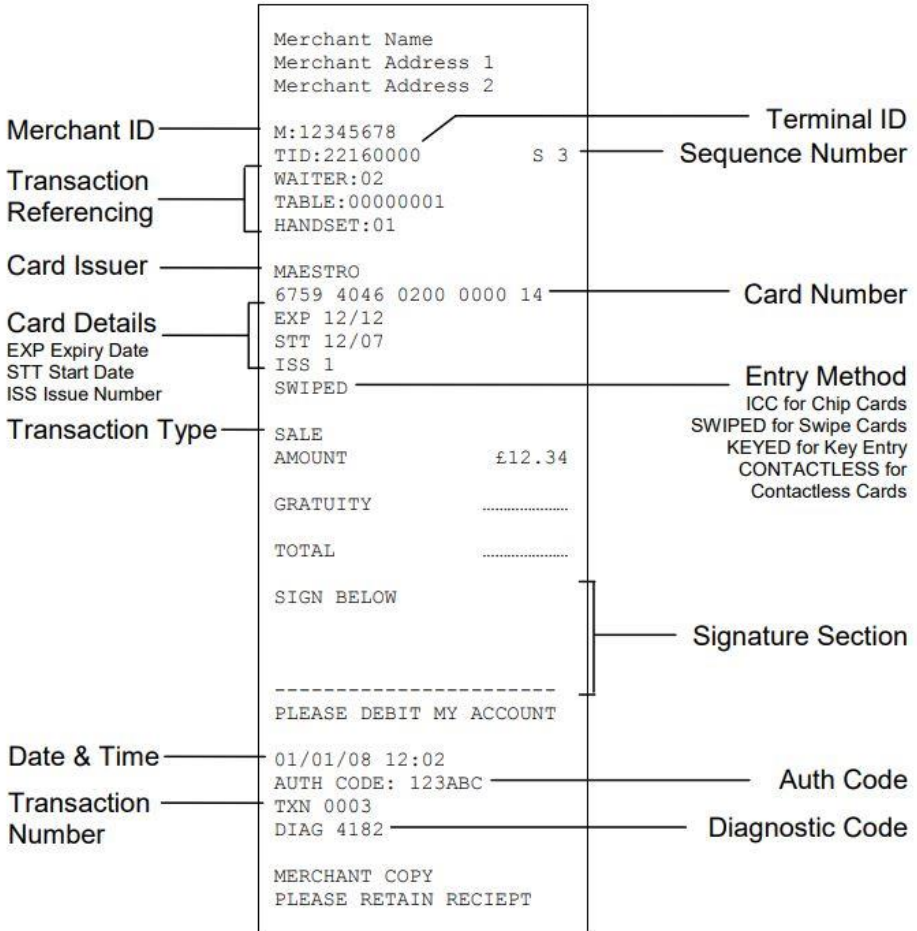

Inserted Cards with Signature (Merchant Copy)

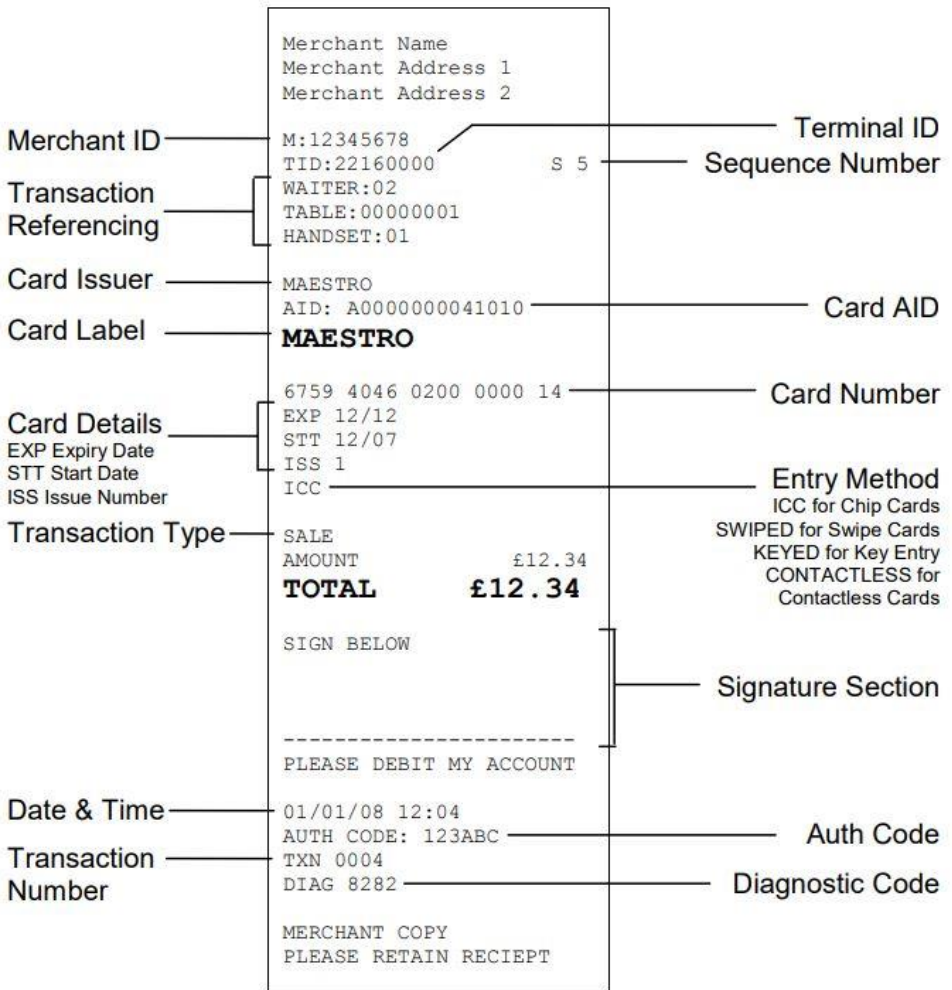

Inserted Cards with Signature and Gratuity (Merchant Copy)

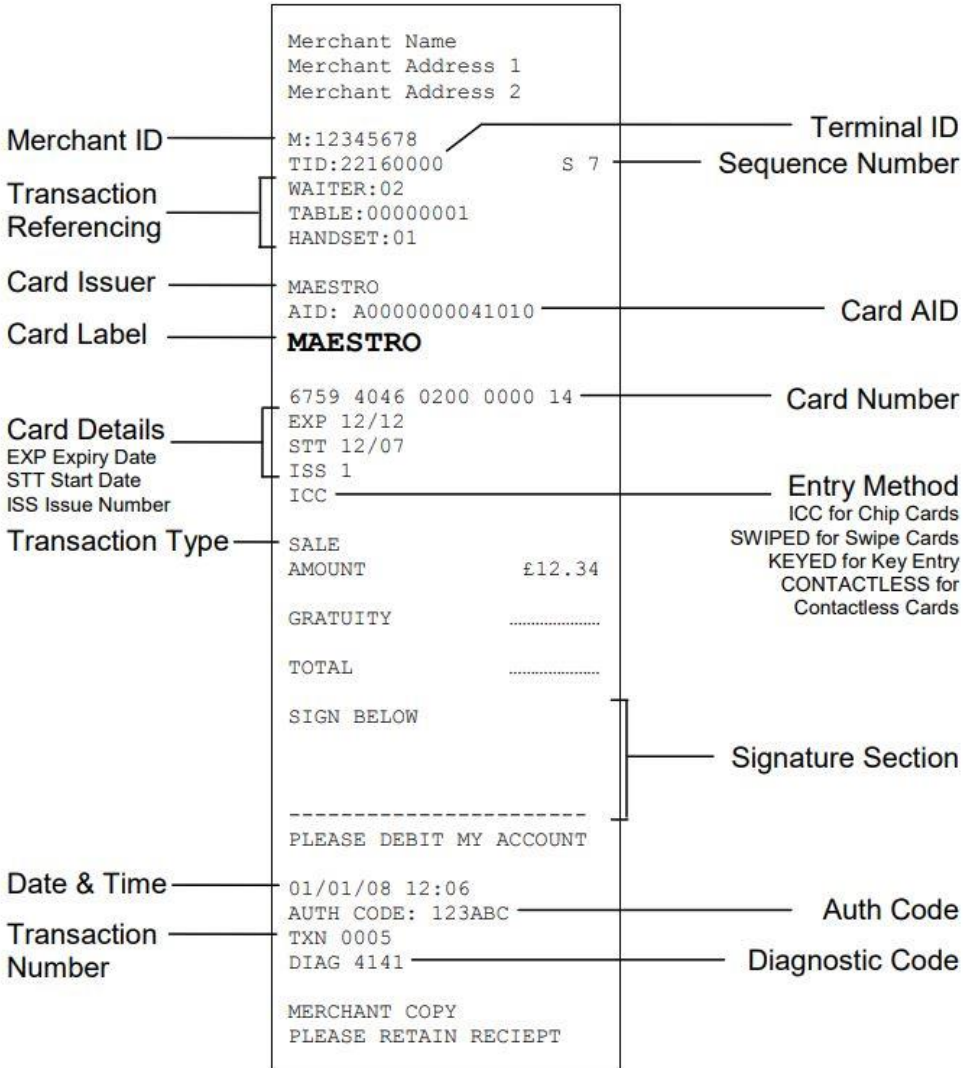

Merchant Copy - PIN Transactions

Inserted Cards with PIN (Merchant Copy)

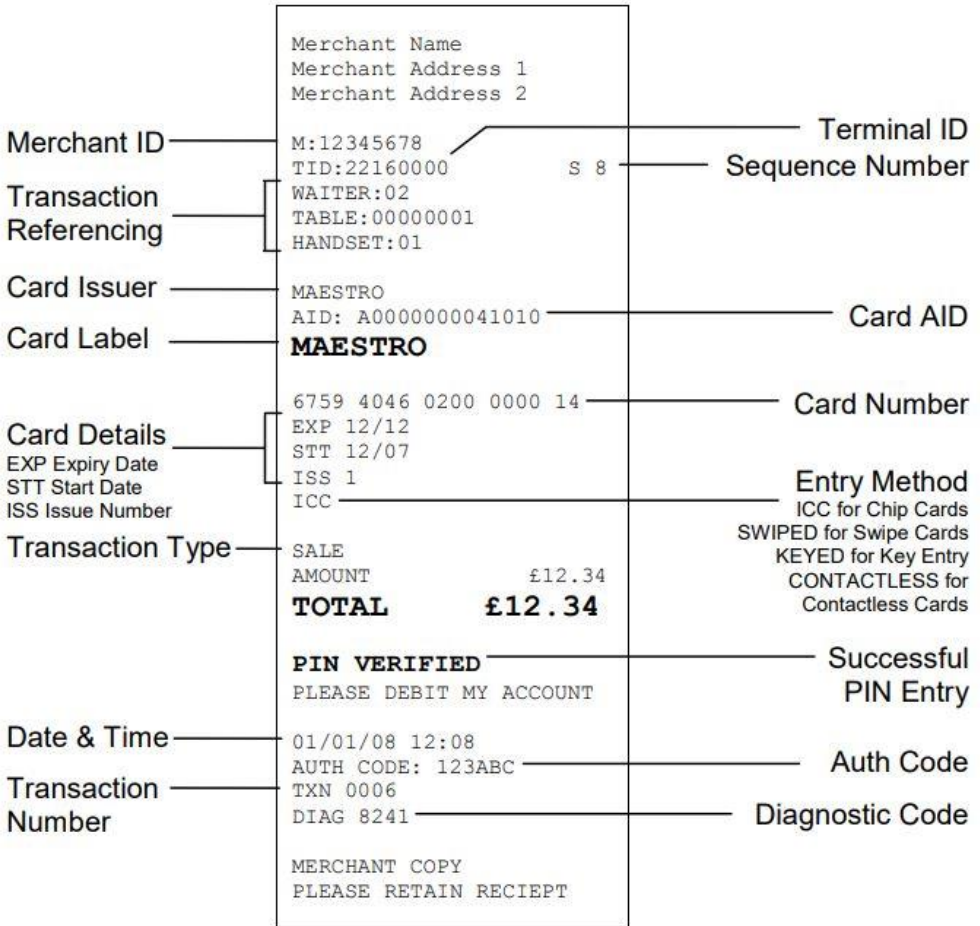

Inserted Cards with PIN and Gratuity (Merchant Copy)

	Merchant Name		
	Merchant Address 1		
	Merchant Address 2		
Merchant ID	M:12345678	Terminal ID	S 9
	TID:22160000	Sequence Number	
Transaction Referencing	WAITER:02		
	TABLE:00000001		
	HANDSET:01		
Card Issuer	MAESTRO		
Card Label	AID: A0000000041010	Card AID	
	MAESTRO		
Card Details	6759 4046 0200 0000 14	Card Number	
EXP Expiry Date	EXP 12/12		
STT Start Date	STT 12/07		
ISS Issue Number	ISS 1		
Transaction Type	ICC	Entry Method	ICC for Chip Cards
	SALE		SWIPED for Swipe Cards
	AMOUNT £12.34		KEYED for Key Entry
	GRATUITY £1.00		CONTACTLESS for Contactless Cards
	TOTAL £13.34		
	PIN VERIFIED	Successful PIN Entry	
	PLEASE DEBIT MY ACCOUNT		
Date & Time	01/01/08 12:10		
Transaction Number	AUTH CODE: 123ABC	Auth Code	
	TXN 0007		
	DIAG 8282	Diagnostic Code	
	MERCHANT COPY		
	PLEASE RETAIN RECIEPT		

Merchant Copy - Contactless Transactions

Contactless Cards (Merchant Copy)

	Merchant Name Merchant Address 1 Merchant Address 2	
Merchant ID	M:12345678	Terminal ID
	TID:22160000	S 14
Transaction Referencing	WAITER:02 TABLE:00000001 HANDSET:01	Sequence Number
Card Issuer	MAESTRO	
Card Label	AID: A0000000041010 MAESTRO	Card AID
Card Details	6759 4046 0200 0000 14	Card Number
EXP Expiry Date	EXP 12/12	
STT Start Date	STT 12/07	
ISS Issue Number	ISS 1	
Transaction Type	SALE AMOUNT £1.23 TOTAL £1.23	Entry Method ICC for Chip Cards SWIPED for Swipe Cards KEYED for Key Entry CONTACTLESS for Contactless Cards
	NO CARDHOLDER VERIFICATION	Successful Contactless Read
Date & Time	01/01/08 12:15	
Transaction Number	AUTH CODE: 123ABC TXN 0017 DIAG 52	Auth Code
		Diagnostic Code
	MERCHANT COPY PLEASE RETAIN RECIEPT	

Customer Copy – Keyed Transactions

Keyed Cards with Signature (Customer Copy)

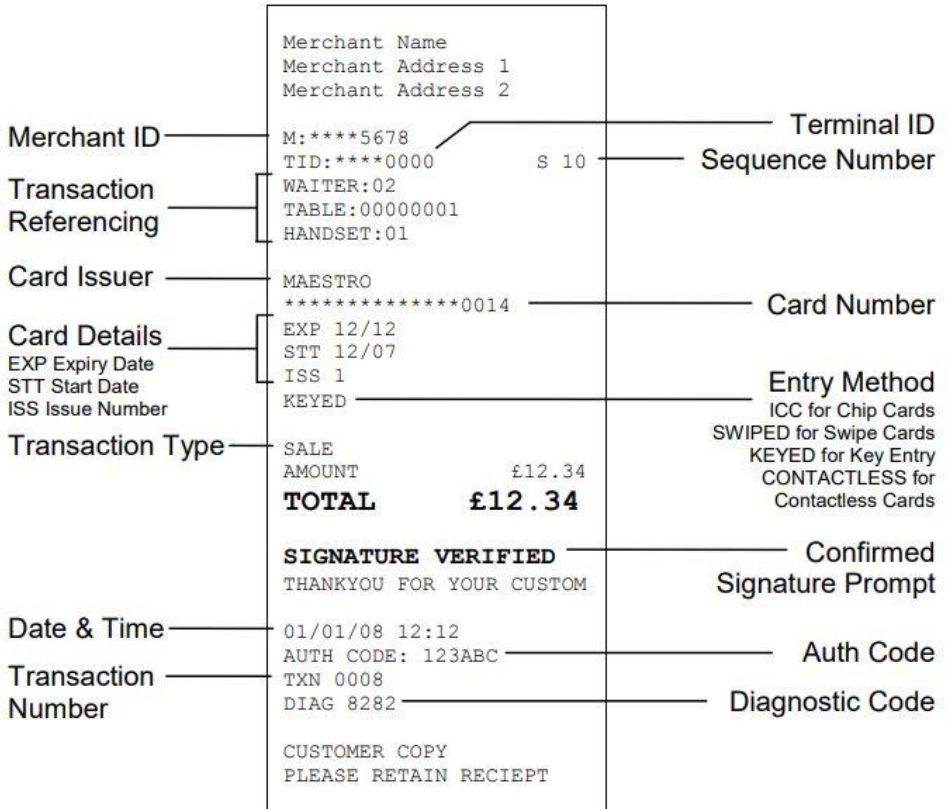

For security the full card number is not displayed on the customer copy.

Customer Copy – Inserted Card

Inserted Cards with PIN (Customer Copy)

	Merchant Name Merchant Address 1 Merchant Address 2	
Merchant ID	M:****5678	Terminal ID
	TID:****0000 S 11	Sequence Number
Transaction Referencing	WAITER:02 TABLE:00000001 HANDSET:01	
Card Issuer	MAESTRO	
Card Label	AID: A0000000041010 MAESTRO	Card AID
Card Details	*****0014	Card Number
EXP Expiry Date	EXP 12/12	
STT Start Date	STT 12/07	
ISS Issue Number	ISS 1	Entry Method
Transaction Type	ICC	ICC for Chip Cards SWIPED for Swipe Cards KEYED for Key Entry CONTACTLESS for Contactless Cards
	SALE AMOUNT £12.34 TOTAL £12.34	
	PIN VERIFIED THANKYOU FOR YOUR CUSTOM	Successful PIN Entry
Date & Time	01/01/08 12:14	
Transaction Number	AUTH CODE: 123ABC TXN 0009 DIAG 4141	Auth Code Diagnostic Code
	CUSTOMER COPY PLEASE RETAIN RECIEPT	



For security the full card number is not displayed on the customer copy.

Customer Copy – Contactless

Contactless Cards (Customer Copy)

	DUPLICATE		
	Merchant Name		
	Merchant Address 1		
	Merchant Address 2		
Merchant ID	M:****5678	S 14	Terminal ID
	TID:****0000		Sequence Number
Transaction Referencing	WAITER:02		
	TABLE:00000001		
	HANDSET:01		
Card Issuer	MAESTRO		
	*****0014		Card Number
Card Details	EXP 12/12		
EXP Expiry Date	STT 12/07		
STT Start Date	ISS 1		
ISS Issue Number	CONTACTLESS		Entry Method
Transaction Type	SALE		ICC for Chip Cards
	AMOUNT	£1.23	SWIPED for Swipe Cards
	TOTAL	£1.23	KEYED for Key Entry
			CONTACTLESS for Contactless Cards
	NO CARDHOLDER VERIFICATION		Successful Contactless Read
	THANKYOU FOR YOUR CUSTOM		
Date & Time	01/01/08 12:15		
	AUTH CODE: 123ABC		Auth Code
Transaction Number	TXN 0017		
	DIAG 52		Diagnostic Code
	CUSTOMER COPY		
	PLEASE RETAIN RECEIPT		



For security the full card number is not displayed on the customer copy.



Only the merchant copy is printed during a contactless transaction. If the customer requires a receipt then the customer copy can be printed any time until another transaction is performed by pressing the **F1** key.

Customer Copy – Pre-Paid Cards

Pre-Paid Cards (Customer Copy)

	Merchant Name Merchant Address 1 Merchant Address 2	
Merchant ID	M:****5678 TID:****0000	Terminal ID Sequence Number
Transaction Referencing	WAITER:03 TABLE:00000004 HANDSET:01	S 5
Card AID & Label	VISA DEBIT AID: A0000000031010 VISA DEBIT	Card Issuer
Card Details	*****1111 EXP 12/16 STT 12/10 ISS 1 ICC	Card Number Entry Method
Transaction Type	SALE AMOUNT £21.34 TOTAL £21.34	ICC for Inserted Cards SWIPED for Swiped Cards KEYED for Keyed Cards CONTACTLESS for Contactless Cards
Pre-Paid Card Available Balance	AVAILABLE: £1000.00	
	PIN VERIFIED THANKYOU FOR YOUR CUSTOM	Successful PIN Entry
Date & Time	01/01/11 12:11 AUTH CODE: 123ABC	Auth Code
Transaction Number	TXN 0004 DIAG 8241	Diagnostic Code
	MERCHANT COPY PLEASE RETAIN RECEIPT	



For security the full card number is not displayed on the customer copy.





The Pre-Paid Card available balance is shown only on the customer copy.

Declined and Void Receipts

If the transaction is declined by the acquirer or by an inserted Chip card, the terminal will print a declined receipt, as shown below. The text printed below the Date and Time is the response from message from the acquirer.

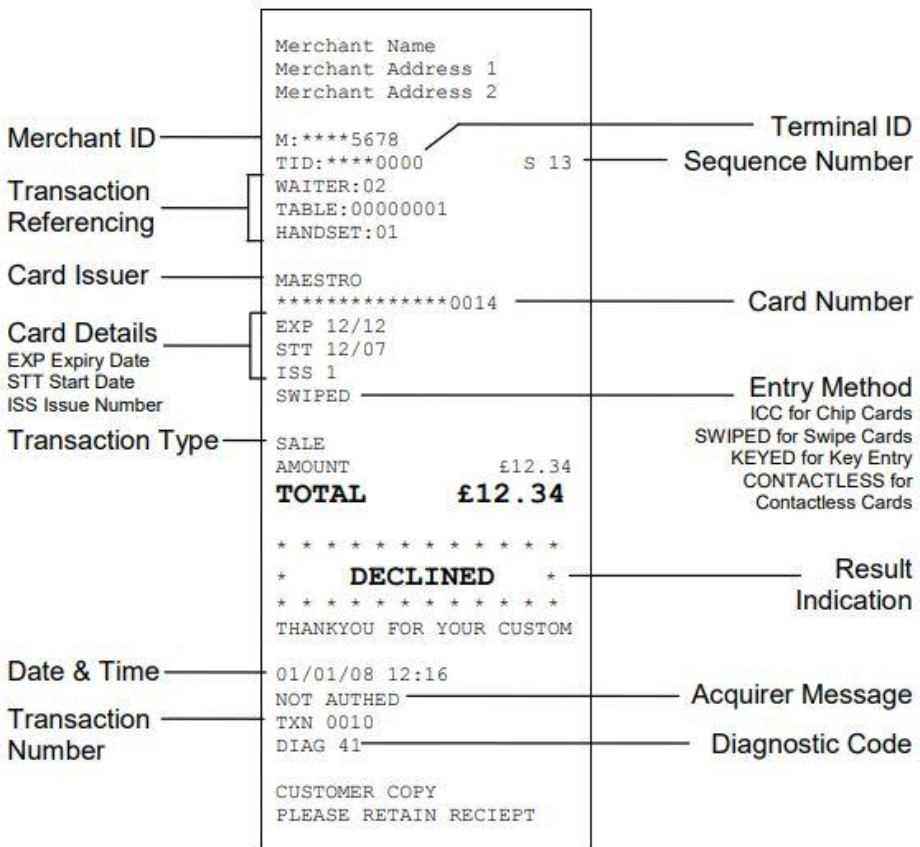
Example Declined Receipt (Customer Copy)



 For security the full card number is not displayed on the customer copy.

VOID	If the Result Indication shows VOID then the transaction has been cancelled by the operator.
CANCELLED	If the transaction was cancelled by pressing the <u>cancel</u> key, the message below the date/time will read CANCELLED.
SIGNATURE INVALID	If the transaction was cancelled by the operator selecting NO to the signature check, then the text below the Date and Time will read SIGNATURE INVALID.

Transaction Referencing

Your terminal is not pre-configured to allow for Transaction Referencing. If you would like Transaction Referencing to be enabled on your terminal please contact the terminal Helpdesk.

Transaction Referencing can be used to reference each transaction's ticket to a specific terminal operator, or location. The most common use of Transaction Referencing is in the leisure industry for use by Waiters (operator) and Tables (location).

The labels for these references are completely customisable for your needs, so you could have Room Number (in a Hotel), or Invoice ID (in an office based business), or maybe Customer ID. Please contact the terminal Helpdesk if you wish to customise these labels.

OPERATOR	Operator ID (Waiter ID) is printed on both the merchant and customer copy of the transaction receipts. You will also have a sub-report on your X/Z Balance reports which breakdown the transactions including gratuities (if enabled) by each operator. Operator ID has a range from 1 to 99.
LOCATION	Location ID (Table ID) is printed on both the merchant and customer copy of the transaction receipts. Location ID can be up to twenty-five characters in length and formed of both letters and numbers if required.
HANDSET	Handset ID is enabled by default, and allows you to simply reference which terminal was used to take the transaction, when you have more than one terminal in use in your business. The default value of 01 can be changed, refer to the section entitled Supervisor Menus Error! Reference source not found.for more details.

5. Reports

Your terminal can produce a number of reports to aid in banking and transaction management.

END OF DAY	One-touch End of Day procedure.
BANKING	A reconciliation report with the acquirers.
X BALANCE	A transaction total print without a reset.
Z BALANCE (!)	A transaction total print with a reset.

The time span over which the X and Z Balance reports cover is defined simply when the reports are done, but it is important that a Banking or End of Day report is done at least once each trading day.



At the end of each trading day you should perform an End of Day report (or a Banking and Z Balance report). This will give you a full record of all business done that day and will allow for the fastest possible processing of funds into your merchant account.

If you do not complete an End of Day report, monies may not be collected from the customer and will lead to a delay in you receiving funds.

There are several common features across the totals and sub-totals on all of the reports that are available.

- DR indicates that the value of transactions shown is in your favour - the value shown will be debited from customers.
- CR indicates that the value of transactions shown is **not** in your favour - the value shown will be credited to customers.
- The number of transactions that add up to the total shown will always be shown on the left of the value.
- Any gratuity and cashback amounts are included in the TOTAL and SUB-TOTAL, as well as in the breakdown by transaction type (i.e. Sales or Refunds).



Always check that your paper roll is not about to run out, before doing any reports.

End of Day Report

Your terminal is provided with an End of Day report that allows you to print both the Z Balance and the Banking reports from the one place. This simplifies your end of day procedure and ensures that you do the correct reports each day.

The End of Day report prints first the Z Balance, followed by Banking for all acquirers. After the report has printed you should ensure that the Banking report shows **TOTALS CONFIRMED** for each acquirer, and that the totals are consistent with the Z Balance report.

To perform an End of Day report press the menu key **twice**, then choose **REPORTS** by pressing the F1 key. You will be asked to type your supervisor password, then press enter, choose **END OF DAY** by pressing the F1 key.

- ✓ **MENU, MENU, F1, [password], ENTER, F1**

Reports performed by the End of Day function will look exactly the same as if they were done separately, however above each report title will be the title **END OF DAY**.

Example End of Day report

```
END OF DAY
Z BALANCES
Totals Reset

Merchant Name
Merchant Address 1
Merchant Address 2
```

```
END OF DAY
BANKING

Merchant Name
Merchant Address 1
Merchant Address 2
```

Please refer to the following sections entitled **Banking Report** and **Z Balance** for more details on the contents of each report.

Banking Report

Performing a Banking report reconciles the transaction totals held in the terminal with the totals held by each acquirer. The terminal may need to contact some or all of the acquirers to complete this report.

Transactions are listed by acquirer, and are also shown by card type under that acquirer. Reconciliations are done by sessions; these sessions are tracked by both the terminal and the acquirer.

The totals listed under `PREVIOUS SESSION` were carried out during the previous reconciliation session and have already been processed by the acquirer.

The totals listed under `CURRENT SESSION` were carried out during the current reconciliation session and will be processed by the acquirer at the end of the session.

To understand the concept of sessions, the `PREVIOUS SESSION` on today's reports will be the same as the `CURRENT SESSION` on yesterday's report, and so on. If these totals do not match then you may be doing your report outside of the acquirer's specified banking window.



You should contact your acquirer(s) to find out when your specified banking window is, if you do your Banking report outside of this time then your reports may not reconcile correctly.

The result for each acquirer's reconciliation is shown below the acquirer's name.

TOTALS CONFIRMED	Shown if the totals held by the acquirer and the terminal agree.
TOTALS NOT AGREED	Shown if the totals held by the acquirer and the terminal do not agree. The report will show the totals held by the terminal and the acquirer separately to show the difference. You should contact the acquirer to ensure that all expected funds have been transferred.
CANNOT CONFIRM TOTALS	Shown when the terminal cannot contact the acquirer to check the totals. The diagnostic code printed will indicate the reason for the communications failure.

To perform a Banking report for ALL acquirers press the menu key **twice**, then choose **REPORTS** by pressing the F1 key. You will be asked to type your supervisor password, then press enter, choose **BANKING** by pressing the F2 key, followed by the F1 key to choose **ALL**.

- ✓ **MENU, MENU, F1, [password], ENTER, F2, F1**

To perform a Banking report for a **SINGLE** acquirer press the menu key **twice**, then choose **REPORTS** by pressing the F1 key. You will be asked to type your supervisor password, then press enter, choose **BANKING** by pressing the F2 key, followed by the F4 key to choose **SINGLE**. Press F4 repeatedly for **NEXT** until the acquirer required is displayed, select this by pressing enter.

- ✓ **MENU, MENU, F1, [password], ENTER, F2, F4**



The Banking report is a constitutional part of the End of Day Report. If you do an End of Day report then you do not need to perform a separate Banking report. If you do not complete an End of Day report (or the Banking and Z Balance separately), money may not be collected from the customer and will lead to a delay in you receiving

Example Banking report (Acquirer 1)

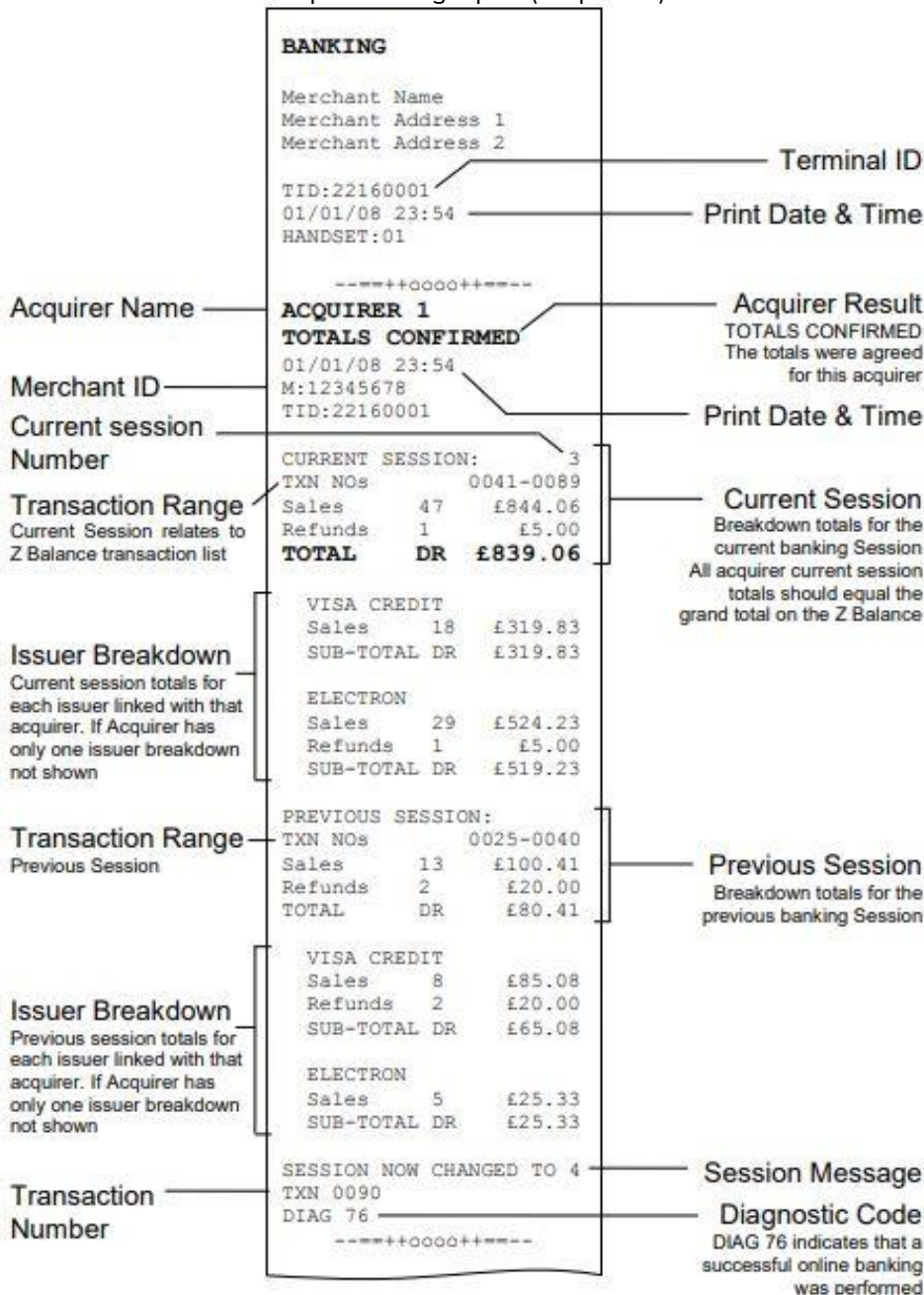

Example Banking report continued (Acquirer 2)

<p>Acquirer Name</p> <p>Merchant ID</p> <p>Current session Number</p> <p>Transaction Range Current Session relates to Z Balance transaction list</p> <p>Transaction Range Previous Session</p> <p>Stored Trans. If any transactions are stored in the terminal and it was unable to go online they will be shown.</p> <p>Transaction Number</p>	<pre> -----+0000+----- ACQUIRER 2 TOTALS UNCONFIRMED 01/01/08 23:55 M:87654321 TID:22160001 CURRENT SESSION: 2 TXN NOs 0039-0042 Sales 1 £10.00 Refunds 1 £20.00 TOTAL CR £10.00 PREVIOUS SESSION: TXN NOs 0025-0038 Sales 8 £827.19 Refunds 2 £40.00 TOTAL DR £787.19 STORED TRANSACTIONS: TXN NOs 0043-0044 Refunds 1 £15.00 TOTAL CR £15.00 TXN 0046 DIAG 828282 -----+0000+----- </pre>	<p>Acquirer Result TOTALS UNCONFIRMED The totals were not checked for this acquirer</p> <p>Print Date & Time</p> <p>Current Session Breakdown totals for the current banking Session All acquirer current session totals should equal the grand total on the Z Balance</p> <p>Previous Session Breakdown totals for the previous banking Session</p> <p>Diagnostic Code DIAG 828282 indicates that the acquirer was unable to be contacted due to three communications errors</p>
---	--	--

i **TOTALS UNCONFIRMED** means that the totals were in balance after the last online transaction so are probably correct, but they have not been checked during the reconciliation because, in this case, a communications error (see the Diagnostic Code). If the reconciliation is attempted again and the terminal again fails to contact the acquirer, the report will indicate **CANNOT CONFIRM TOTALS**.

i **Stored Transactions** are only printed if they are stored and the terminal could not contact the acquirer for reconciliation. They are only added to the session totals after they have been transmitted to the acquirer.

i This acquirer has only one issuer, so no breakdown by issuer is shown.

Example Banking report continued (Acquirer 3)

Acquirer Name	<pre> -----+----- ACQUIRER 3 TOTALS NOT AGREED CALL ACQUIRER 01/01/08 23:56 M:11223344 TID:22160001 </pre>	Acquirer Result TOTALS NOT AGREED The terminal totals did not match the acquirers records for this acquirer
Merchant ID	<pre> -----+----- HOST AND TERMINAL TOTALS DO NOT AGREE: ACQUIRER 3 Sales 8 £787.19 TOTAL DR £787.19 Merchant Name NO BUSINESS </pre>	Print Date & Time
Disputed Totals Only shown when totals are not agreed. The totals returned by the acquirer are printed together with the terminal totals for comparison	<pre> -----+----- CURRENT SESSION: NO BUSINESS </pre>	Current Session The current session totals indicate that there has been no transactions for this acquirer. The issuer breakdown is not shown for NO BUSINESS
Transaction Range Previous Session	<pre> PREVIOUS SESSION: TXN Nos 0005-0015 Sales 2 £50.00 Refunds 1 £10.00 TOTAL DR £40.00 </pre>	Previous Session Breakdown totals for the previous banking Session
Transaction Number	<pre> TXN 0016 DIAG 7376 </pre>	Diagnostic Code DIAG 7376 indicates that the totals are out of balance (73) and a successful online banking was performed (76)
Report Summary If some or all of the acquirers give a response other than TOTALS CONFIRMED then the summary of the issues is shown	<pre> -----+----- CAUTION Acquirers attempted 3 Agreed 1 Not Agreed 1 Unconfirmed 1 REPORT COMPLETE </pre>	

i The acquirer totals will match the current session totals if the Banking report is completed daily during the banking window, if it is not completed in this way then this total may differ.

i This acquirer has had no business, so no breakdown by issuer is shown.

X Balance Report

The X Balance report is sometimes referred to as an End of Shift Balance report. This is because it allows you to print a total of all transactions performed since the last Z Balance report. The X Balance may be printed at any time throughout the day.

Transactions are listed by card type, and by Operator ID (Waiter ID for example, if enabled) showing transactions and gratuities (if enabled) by each operator.

A list of all transactions done since the last Z Balance was completed is also shown.



The totals within the terminal will not be reset after printing a X Balance.

To perform an X Balance report press the menu key **twice**, then choose **REPORTS** by pressing the F1 key. You will be asked to type your supervisor password, then press enter, choose **X BALANCE** by pressing the F3 key.

✓ **MENU, MENU, F1, [password], ENTER, F3**

The X Balance report is exactly the same as the Z Balance excepting the totals **are not** reset.

Example X Balance report

```
X BALANCES  
Totals Not Reset  
  
Merchant Name  
Merchant Address 1  
Merchant Address 2
```

Please refer to the following section entitled **Z Balance Report** for more details on the contents of the X Balances report.

Z Balance Report

The Z Balance report is sometimes referred to as an End of Day Balance report. This is because it allows you to print a total of all transactions performed since the last Z Balance report. The Z Balance should be printed at end of each trading day.

Transactions are listed by card type, and by Operator ID (Waiter ID for example, if enabled) showing transactions and gratuities (if enabled) by each operator.

A list of all transactions done since the last Z Balance was completed is also shown.



The totals within the terminal will be reset after printing a Z Balance.

To perform an Z Balance report press the menu key **twice**, then choose **REPORTS** by pressing the F1 key. You will be asked to type your supervisor password, then press enter, choose **Z BALANCE (!)** by pressing the F4 key.

✓ **MENU, MENU, F1, [password], ENTER, F4**

The Z Balance report is exactly the same as the X Balance excepting the totals **are** reset in the terminal once the report is complete. The terminal will display **PLEASE WAIT** and a short progress indication while the totals are being reset.



The Z Balance report is a constitutional part of the End of Day Report. If you do an End of Day report then you do not need to perform a separate Z Balance report.

If you do not complete an End of Day report (or the Banking and Z Balance separately), money may not be collected from the customer and will lead to a delay in you receiving funds.

Example Z Balance Report (Totals and Breakdown by Issuer)

Z BALANCES	
Totals Reset	
Merchant Name	
Merchant Address 1	
Merchant Address 2	
TID:22160001	
01/01/08 23:47	
HANDSET:01	
GRAND TOTALS	
Since 31/12/07 23:50	
Sales	48 £854.06
Refunds	4 £40.00
TOTAL	DR £814.06
Includes	
Tips	30 £61.24
Cashback	5 £50.00
-----+-----	
BREAKDOWN BY ISSUER	
Since 31/12/07 23:50	
AMERICAN EXPRESS	
Sales	1 £10.00
Refunds	1 £35.00
SUB-TOTAL	CR £25.00
VISA CREDIT	
Sales	18 £319.83
SUB-TOTAL	DR £319.83
ELECTRON	
Sales	29 £524.23
Refunds	1 £5.00
SUB-TOTAL	DR £519.23
-----+-----	

Terminal ID

Print Date & Time

Date of Last
Z Balance Done

Total

Grand Totals

Details all business done
since the last Z Balance

Includes

Shows the total value of
Tips and Cashback (if
enabled) included within
the total shown above

Date of Last
Z Balance Done

Issuer Breakdown

Breaks down all business
done since last Z Balance
for each issuer (card type)

For clarity Tips and
Cashback are not shown
All SUB-TOTAL values
add up to the TOTAL
shown above

Values shown as CR must
be subtracted to give the
final total

Example Z Balance Report continued (Breakdown by Waiter and Transaction Listing)

Z BALANCES	
Totals Reset	
Merchant Name	
Merchant Address 1	
Merchant Address 2	
TID:22160001	
01/01/08 23:47	
HANDSET:01	
GRAND TOTALS	
Since 31/12/07 23:50	
Sales	48 £854.06
Refunds	4 £40.00
TOTAL	DR £814.06
Includes	
Tips	30 £61.24
Cashback	5 £50.00
-----++0000++-----	
BREAKDOWN BY ISSUER	
Since 31/12/07 23:50	
AMERICAN EXPRESS	
Sales	1 £10.00
Refunds	1 £35.00
SUB-TOTAL	CR £25.00
VISA CREDIT	
Sales	18 £319.83
SUB-TOTAL	DR £319.83
ELECTRON	
Sales	29 £524.23
Refunds	1 £5.00
SUB-TOTAL	DR £519.23
-----++0000++-----	

Terminal ID

Print Date & Time

Date of Last Z Balance Done

Total

Includes

Shows the total value of Tips and Cashback (if enabled) included within the total shown above

Date of Last Z Balance Done

Grand Totals

Details all business done since the last Z Balance

Issuer Breakdown

Breaks down all business done since last Z Balance for each issuer (card type)

For clarity Tips and Cashback are not shown

All SUB-TOTAL values add up to the TOTAL shown above

Values shown as CR must be subtracted to give the final total

Stored Report

A Stored Transaction report may be printed to show how many transactions are stored in the terminal, awaiting transmission to the host.

Up to five transactions may be stored in the terminal per acquirer. A transaction may be stored after voice referral, or by using the Forced Transaction or Hotel Mode Completion functions.



Do not print this report unless instructed to do so by the terminal Helpdesk.

To perform a Stored report for ALL acquirers press the menu key **twice**, then choose REPORTS by pressing the F1 key. You will be asked to type your supervisor password, then press enter, press the menu key **once more**, choose STORED by pressing the F1 key, followed by the F1 key to choose ALL.

- ✓ MENU, MENU, F1, [password], ENTER, MENU, F1, F1

To perform a Stored report for a SINGLE acquirer press the menu key **twice**, then choose REPORTS by pressing the F1 key. You will be asked to type your supervisor password, then press enter, press the menu key **once more**, choose STORED by pressing the F1 key, followed by the F4 key to choose SINGLE. Press F4 repeatedly for NEXT until the acquirer required is displayed, select this by pressing enter.

- ✓ MENU, MENU, F1, [password], ENTER, MENU, F1, F4

TMS Report

Approximately once a month your terminal will call the Terminal Management System (TMS) to receive any updates to the software, details of new card schemes, and any changes to your configuration. This call will take place automatically, normally outside of standard trading hours.

After the TMS call has taken place your terminal will print a TMS report, indicating if the communication was successful or has failed.

If the TMS call is interrupted part way through downloading a new or updated configuration file, for example due to a communications problem, the terminal will set it into a `NOT READY` state, and will not be usable until the file has been downloaded.

If your terminal displays the `NOT READY` status message then your terminal is not initialised. Press menu once, and choose the `SETUP` menu option. You should contact the terminal Helpdesk if the problem persists after a successful TMS call.

Example successful TMS report

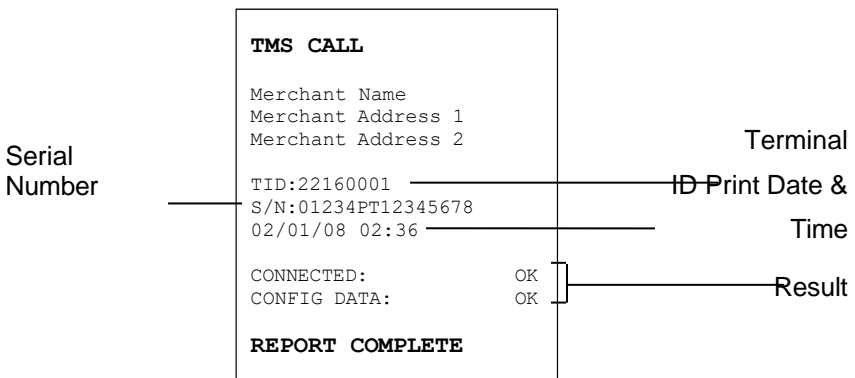

The status of `CONNECTED` may be; `OK` (if successfully connected to the TMS), or `FAIL` (if unable to connect to the TMS).

The status of `CONFIG DATA` may be; `OK` (if download was successful), `FAIL` (if download was not successful), or `NOT REQUIRED` (if no update was required).

6. Supervisor Functions

Supervisor Password

The Supervisor password is designed to limit access to the Supervisor functions (such as the Supervisor Menus, or Refund transactions) on the terminal to those who have access to the password.

Your terminal is shipped with an initial default password of **01483**, but is configured so that a change of this password is required before you process any transactions. If you forget your password, please contact the terminal Helpdesk who will be able to reset the password back to the default.



The following passwords are not valid choices for your Supervisor password: 01483, 1234, 0000, or 9999.

Any other numerical password of four or more digits will be a valid Supervisor password.



The Supervisor password allows entry into the Refund option on the terminal.

To change your Supervisor password press the menu key **twice**, then choose SUPERVISOR by pressing the F3 key. You will be asked to type your current supervisor password (i.e. 01483), then press enter, choose PASSWORD by pressing the F2 key, followed by the F4 key to choose CHANGE PWD.

✓ MENU, MENU, F3, [password], ENTER, F2, F4

You will need to enter your new numerical password (4 digits or more) **twice**, pressing the enter key after each input, before the Supervisor password is updated to this new value.



If your terminal is lost or stolen you should contact the terminal Helpdesk immediately.

You are strongly advised to ensure that privileged access to your terminal (including access to the Supervisor password) is only granted to staff that have been independently verified as being trustworthy.

Supervisor Password Change (Initial Transaction)

If you have not changed the Supervisor password before you process your first transaction the terminal will prompt you to change the password from the default during the transaction.



A New Password
Must Be Selected

During the transaction, you will be prompted that the password needs to be changed, press any key to continue.

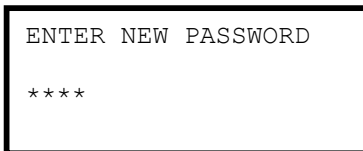

ENTER NEW PASSWORD

Enter a new password and press the enter key.

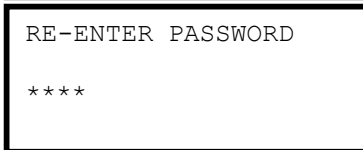

RE-ENTER PASSWORD

Re-enter the new password and press the enter key.

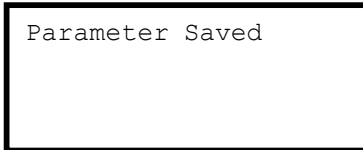

Parameter Saved

A confirmation will be shown if the two entries match and the password has been changed.

The terminal will continue as normal, refer to the instructions for transaction type that you chose to complete the transaction.

Refund Password

Your terminal is configured to use the Supervisor password to protect both the Refund and the Supervisor functions. If you would like a separate password enabled in order to protect the Refund function please contact the terminal Helpdesk.

This feature could be used to allow one member of staff the added ability to perform a Refund; while allowing another member(s) of staff the ability to perform the Supervisor functions.

Supervisor Menus

The Supervisor menus allow access to various management functions in your terminal. To be able to access the Supervisor menu, you must use the Supervisor password.

To access the Supervisor menus press the menu key **twice**, then choose SUPERVISOR by pressing the F3 key. You will be asked to type your current supervisor password, and confirm this by pressing the enter key.

✓ MENU, MENU, F3, [password], ENTER

Once you have access to the Supervisor menus, press the menu key to cycle through the various menu screens.

The next section contains a summary of the Supervisor functions and how to access them, and what they do.



Some Supervisor functions must only be used when instructed to do so by the terminal Helpdesk.

First Supervisor Menu Screen

HANDSET ID	<p>F1 Allows the <code>HANDSET ID</code> value displayed on the idle screen and printed on each ticket to be set. The default value is 01.</p>
PASSWORD	<p>F2 Allows the various passwords in the terminal to be reset or changed. Enters the <code>PASSWORD</code> menu – see next section.</p>
CONFIG	<p>F3 Allows the access to various extended configuration options. Enters the <code>CONFIG</code> menu - see next section.</p>
LOGON	<p>F4 Allows the terminal to make a test call to some or all of the acquirers loaded on the terminal. Do not use this feature unless instructed to do so by the terminal Helpdesk.</p>

Second Supervisor Menu Screen (Press menu once)

SHORTCUT	<p>Allows access to advanced configuration options.</p> <p>F1 Do not use this feature unless instructed to do so by the terminal Helpdesk.</p>
TIPS	<p>F2 Allows the Gratuity/Tip mode to be switched on and off. Setting <code>TIPS</code> to <code>ON</code>, sets <code>OP MODE</code> to <code>LATE</code>.</p>
OP MODE	<p>Allows the setting of when the terminal will contact the acquirer for authorisation during the transaction. Gratuity/Tip mode is only available in <code>LATE</code> mode. Setting <code>OP MODE</code> to <code>EARLY</code>, sets <code>TIPS</code> to <code>OFF</code>.</p> <p>F3</p>
CALL-TMS	<p>Immediately sets off a configuration data call to the Terminal Management System (TMS). Do not use this feature unless instructed to do so by the terminal Helpdesk.</p> <p>F4</p>

Third Supervisor Menu Screen (Press menu twice)

INTL	F1 Allows the international dialling code to be set. Do not use this feature unless instructed to do so by the terminal Helpdesk.
SALETYPE	F2 Allows the default transaction type to be set, so the transaction type will begin as soon as a card is swiped or inserted from the idle screen. If REFUND is set then the Supervisor password check will not be done.
TERMPARAM	F3 Allows the setting of internal terminal options. Do not use this feature unless instructed to do so by the terminal Helpdesk.
UPGRADE	Immediately sets off a software upgrade call to the Terminal Management System (TMS). Do not use this feature unless instructed to do so by the terminal Helpdesk.

Fourth Supervisor Menu Screen (Press menu three times)

DATETIME	F1 Allows the date and time to be set. The date and time is automatically updated when a successful TMS call is made.
BACKLIGHT	F2 Allows the setting of the time taken after a key is pressed before the backlight turns off.
AUTO-OFF	F3 Allows the setting of the time taken after a key is pressed before the terminal enters power save mode.
RELEASE	F4 Prints a summary report of software versions loaded on the terminal. Do not use this feature unless instructed to do so by the terminal Helpdesk.

Supervisor Sub-menus

There are three Supervisor sub-menus. They are the Password menu, the Config menu and the Shortcut menu. They allow access to extended options within the Supervisor menus.

To access the Password menu press the menu key **twice**, then choose SUPERVISOR by pressing the F3 key. You will be asked to type your current supervisor password, and confirm this by pressing the enter key, and choose PASSWORD by pressing the F2 key.

- ✓ MENU, MENU, F3, [password], ENTER, F2

Below is a summary of the functions within the Password menu and how to access them, and what they do.



Some Supervisor functions must only be used when instructed to do so by the terminal Helpdesk.

Password Menu

DELETE ACQ	F1	Deletes all datasets for one or all acquirers from the terminals memory. Do not use this feature unless instructed to do so by the terminal Helpdesk.
MAC RESET	F2	Allows the Message Authentication Code (MAC) key to be reset to the initial value for one or all acquirers. Do not use this feature unless instructed to do so by the terminal Helpdesk.
TMS RESET	F3	Allows the secure password used for communications to the TMS to be reset to the initial value. Do not use this feature unless instructed to do so by the terminal Helpdesk.
CHANGE PWD	F4	Allows the Supervisor password (and/or Refund password) to be changed. The new password must be used for all future password requests.

To access the Config menu press the menu key **twice**, then choose SUPERVISOR by pressing the F3 key. You will be asked to type your current supervisor password, and confirm this by pressing the enter key, and choose CONFIG by pressing the F3 key.

✓ MENU, MENU, F3, [password], ENTER, F3

Below is a summary of the functions within the Config menu and how to access them, and what they do.



Some Supervisor functions must only be used when instructed to do so by the terminal Helpdesk.

First Config Menu

PRINT EMV	F1	Prints EMV data loaded on the terminal. Do not use this feature unless instructed to do so by the terminal Helpdesk.
PRINT CERTS	F2	Prints Certificates loaded on the terminal. Do not use this feature unless instructed to do so by the terminal Helpdesk.
PSTN PREFIX	F3	Allows the telephone network (PSTN) prefix number to be set. For further information refer to the section entitled <i>Telephone Lines and Broadband</i> .
GSM N/W TEST	F4	Prints a rolling data sheet of the mobile network. Do not use this feature unless instructed to do so by the terminal Helpdesk.

Second Config Menu (Press menu once)

SEL GSM N/W	F1	Allow the selection of a different mobile network. Do not use this feature unless instructed to do so by the terminal Helpdesk.
-------------	-----------	---

To access the Shortcut menu press the menu key **twice**, then choose SUPERVISOR by pressing the F3 key. You will be asked to type your current supervisor password, and confirm this by pressing the enter key. Press the menu key and choose SHORT CUT by pressing the F1 key.

✓ **MENU, MENU, F3, [password], ENTER, MENU, F1**

Below is a summary of the functions within the Shortcut menu, how to access them and what they do.



Some Supervisor functions must only be used when instructed to do so by the terminal Helpdesk.

First Shortcut Menu

CONTACTLESS	F1	Configures the internal/external Contactless Reader support. Do not use this feature unless instructed to do so by the terminal Helpdesk..
PINPAD	F2	Configures the external PINpad support. Do not use this feature unless instructed to do so by the terminal Helpdesk.
EPOS INTERF	F3	Configures the EPOS (till) Interface functionality. Do not use this feature unless instructed to do so by the terminal Helpdesk.
BLUETOOTH	F4	Allows the terminal to be associated to a Bluetooth base. Do not use this feature unless instructed to do so by the terminal Helpdesk.

Second Shortcut Menu (Press menu once)

WIFI SETUP	F1	Configures the WiFi network. Do not use this feature unless instructed to do so by the terminal Helpdesk.
------------	-----------	---

7. Troubleshooting

Frequently Asked Questions

Q What do I do if the customer has forgotten their PIN code?

- If your acquirer allows it, you can perform a PIN Bypass to bypass the entry of the PIN code, by pressing the cancel key followed promptly by the menu key **twice**. If the card allows the PIN Bypass you may find that the acquirer declines the transaction. Transactions taken by PIN Bypass are subject to chargebacks so you should make other careful checks on the card and cardholder as laid out by your acquirer. For more information on the use of PIN Bypass please contact your acquirer.

Q What does it mean when the terminal displays PIN TRIES EXCEEDED?

- The card has been locked after too many failed PIN entry attempts. It may be possible to perform a PIN Bypass. The customer should contact their card issuer to change their PIN, or if they do know it they can unlock it at any ATM.

Q I would like to refer a transaction before I attempt a transaction on the terminal as I am suspicious?

- You should contact the authorisation centre and ask for a `CODE 10 REFERRAL`, this alerts the operator why you are asking for the referral, without arousing suspicion with the customer.

Q My terminal displays `NOT READY` on the idle screen, what do I do?

- Your terminal is not initialised, or has failed an automatic TMS call. Press menu once, and choose the `SETUP` menu option. You should contact the terminal Helpdesk if the problem persists after a successful TMS Call.

Q Every transaction that I take is producing a referral, am I doing something incorrectly?

- You should check that the terminal is correctly plugged into the BT telephone socket and that the telephone line being used is not in use, and works. You should refer to the sections entitled ***Terminal Installation*** and ***Telephone Lines and Broadband*** for further details. If the problem persists you should contact the terminal Helpdesk. If there is a problem with the telephone line you should contact your telecommunications supplier.
- If you are using the GSM/GPRS to communicate, you should check that the SIM Card is installed correctly and that a network name and a good signal indication is displayed on the screen. You should refer to the section entitled ***SIM Card Installation*** for further details. Your terminal may not be able to communicate with the acquirer if the signal is very poor.

Q What does it mean if my terminal displays the message ENTER SIM CODE?

- Only use the SIM Card supplied to you by your terminal supplier. If you have been supplied with a replacement SIM Card (for example a faulty or lost SIM Card) your terminal will request a new activation code. Check the documentation which came with the SIM Card. If you cannot locate the SIM Code then please contact the terminal Helpdesk who will provide you with the SIM Code.

Q What should I do if my terminal fails to display a mobile network name on the screen, even though the correct SIM is inserted correctly?

- You should first try to turn the terminal off, leave for about 30 seconds and turn the terminal back on. If the problem persists you should contact the terminal Helpdesk.

Q What can I do if the terminal does not print anything on the paper, does the ink need replacing?

- Your terminal uses a thermal printer and so does not require any ink. You should ensure that the paper is inserted in the correct orientation, as thermal paper only prints on one side. Refer to the section entitled ***Paper Loading*** for more information. Printing can be tested by using the **DUPLICATE** function to produce a duplicate receipt. Only use approved paper rolls from your terminal supplier. If the printer housing or printer roller is damaged you should contact the terminal Helpdesk.

Q My totals on the Z Balance and Banking reports do not match, what do I do?

- The Z Balance report totals give you a total of all transactions done across all acquirers. The Banking report totals give you the total for each acquirer. You should try to add up all the individual totals across all acquirers on the Banking to try to reconcile with the Z Balance total. The current session totals on the Banking shows all transactions for that session - if you perform the Z Balance and Banking at the same time every trading day this should match the totals on the Z Balance. If you still cannot match the totals you should contact the terminal Helpdesk. Please ensure that you have all relevant reports with you when you call. It is possible that you will be asked for the proceeding day's reports as well.

Q What should I do if I have forgotten my Supervisor password?

- You should first try the default password of 01483, if this is not the password then please contact the terminal Helpdesk who will reset the password back to the default value.

Q I am unable to take contactless transactions, am I doing something incorrectly?

- The contactless option will only become active when the transaction amount is under the contactless limit (e.g. £30.00).
- Not all cards are enabled for contactless transactions, please ensure that the card presented to the terminal is a contactless card, the customer should contact their card issuer if they are unsure.
- Ensure that the contactless card is presented to the contactless card read zone until prompted to remove the card. You can check the card read by observing the lighting of the contactless status lights - the card is read when the confirmation tone is heard and all four lights are lit steadily.

Q A lot of contactless transactions prompt that the card should be inserted or swiped, is this normal?

- It is routine that a contactless card will require a further security check occasionally. If the card is used for a lot of contactless transactions then this should be expected. You should contact the terminal Helpdesk if every contactless card prompts you to do this.

Q Occasionally contactless transactions take longer to complete than normal, what is wrong?

- If your terminal takes a lot of contactless transactions consecutively then approximately once in every five or six transactions the terminal will go online for authorisation. Some cards may also require this type of transaction. If you perform other types of transaction then you may not notice this. You should contact the terminal Helpdesk if every contactless transaction does this.

Screen Messages

During normal operation you may come across a number of screen messages. Some indicate an error, whereas others offer information. Below is a list of some of the messages that you may see on your terminal.

BAD MAC	The security password is mismatched between the terminal and the acquirer, please contact the terminal Helpdesk.
CALL AUTH CENTRE	The transaction has been referred, call the authorisation centre on the number provided on the screen or printed on the receipt.
CANCELLED	The terminal is displaying confirmation that you have cancelled the transaction.
DECLINED	The card issuer or acquirer has declined to authorize the transaction, you should ask for another means of payment.
BAD READ	The inserted card could not be read, check orientation of the card and try again.
BAD SWIPE	The swiped card could not be read, check orientation of the card and try again.
NOT ACCEPTED	The card presented is not configured for the selected transaction type, you should ask for another means of payment.
PROCESSING ERROR	The selected operation is not allowed for the card presented, or the card is faulty. You should ask for another means of payment.
OPERATION NOT ALLOWED	The selected operation has been disabled, is not allowed for the card presented, or the card is faulty. You should ask for another means of payment.
INVALID TRANSACTION	The selected transaction type (e.g. Cashback) may not be active on your merchant account, you should contact your acquirer.
INVALID CARD	The card presented is of a type that is not supported, or is damaged and could not be read, you should ask for another means of payment.
EXPIRED CARD	The card presented is expired, you should ask for another means of payment. If the card is in date check the date and time on the terminal.

PREVALID CARD	The card presented is not yet valid, you should ask for another means of payment. If the card is in date check the date and time on the terminal.
SORRY FOR DELAY... RETRYING	The terminal is unable to contact the acquirer due to a communications error. The terminal will make three dial attempts; if all three attempts should fail the transaction will be referred. You should check the phone line, and contact the terminal Helpdesk if the problem persists.
PRESS ENTER TO RETRY	The first two dial attempts have failed, resolve the issue (e.g. ensure that the phone line is not in use) and press enter to continue for the third and final dial attempt. You should check the phone line, and contact the terminal Helpdesk if the problem persists.
CANNOT CALL HOST TRY PHONE LINE	The terminal is unable to contact the acquirer due to a communications error after three dial attempts. You should check the phone line or network, and contact the terminal Helpdesk if the problem persists
MEMORY xx% FULL DO Z BALANCE	The terminal's memory is becoming full and needs to be cleared. Do a Z Balance to clear the transaction log. Warning will only show when 90% full or more. You should perform the Z Balance at the end of every trading day. If the problem persists after a successful Z Balance, please contact the terminal Helpdesk.

Below is a list of the messages that you may see on the display of your terminal that specifically relate to contactless transactions.

APPROVED	The contactless transaction has been approved.
REFUSED	The contactless transaction has been refused, you should ask for another means of payment.
NOT AUTHORISED	The card, card issuer or acquirer has declined to authorise the transaction, you should ask for another means of payment.
CARD READ FAILURE REPRESENT CARD	The card was removed too soon and the card read has failed. The cardholder should re-present the card. They should not remove the card until prompted to do so
PLEASE PRESENT ONE CARD ONLY	The card was presented with another contactless card and the card read has failed. The cardholder should re-present the card ensuring that it is the only card presented.
INSERT OR SWIPE CARD	The card requires a further security check. The transaction must be completed with cardholder verification (PIN entry or Signature as appropriate).
LOADING TPASS PARAMETERS...	The integrated contactless reader is being updated. This message is displayed during start up, and after your terminal has performed a maintenance call. Please wait a few seconds for the idle screen to be displayed before starting a transaction.

Diagnostic Codes

You may see diagnostic (DIAG) codes at the bottom of transaction receipts and reports. Some indicate an error while others offer information. More than one diagnostic code may be printed. For example DIAG 828282 would indicate three communication failure attempts during a transaction.

10 OR 17	GPRS/IP connection error. Retry transaction. If the problem persists check the network or mobile network, and contact the terminal Helpdesk quoting the diagnostic code
14	SSL certificate missing. Contact the terminal Helpdesk quoting the diagnostic code.
15	Unexpected response after dialling. Check the phone line, if a prefix is required to obtain an outside line refer to the section entitled Telephone Lines and Broadband to programme this into the terminal. If the problem persists contact the terminal Helpdesk quoting the diagnostic code
22	No dial tone. Check the phone line and retry the transaction. If the problem persists contact the terminal Helpdesk quoting the diagnostic code.
31	Line busy. Check the phone line is not in use and retry the transaction. If the problem persists contact the terminal Helpdesk quoting the diagnostic code.
41 OR 44	Call connected but End of Transmission response. The acquirer maybe busy or there was a communication error. Retry transaction. If the problem persists contact the terminal Helpdesk quoting the diagnostic code.
49	Invalid message contents. The selected transaction type (e.g. Cashback) may not be active on your merchant account, you should contact your acquirer. If the problem persists contact the terminal Helpdesk quoting the diagnostic code
52	Offline or Forced Transaction. This is not an error and is for information only. Offline store is full.
53	You should attempt an online transaction, if the problem persists check the phone line, and contact the terminal Helpdesk quoting the full diagnostic code.

61	PIN Bypass attempted. This is not an error and is for information only.
62	PIN tries exceeded. This is not an error and is for information only.
70xx	Error in transaction security. Normally indicates that the MAC code is invalid, contact the terminal Helpdesk quoting the full diagnostic code.
72	Merchant has indicated an invalid signature. This is not an error and is for information only
73	Terminal and host totals do not agree. Do a Banking report, and contact the acquirer if advised to do so. If the problem persists contact the terminal Helpdesk quoting the diagnostic code
76	Terminal completed online reconciliation. This is not an error and is for information only.
82	Modem or communications error. Retry transaction. If the problem persists check the phone line, network or mobile network, and contact the terminal Helpdesk quoting the diagnostic code.
93	Transaction cancelled by the operator. This is not an error and is for information only
98	Bad password on TMS call. Contact the terminal Helpdesk quoting the diagnostic code.

Menu Structure

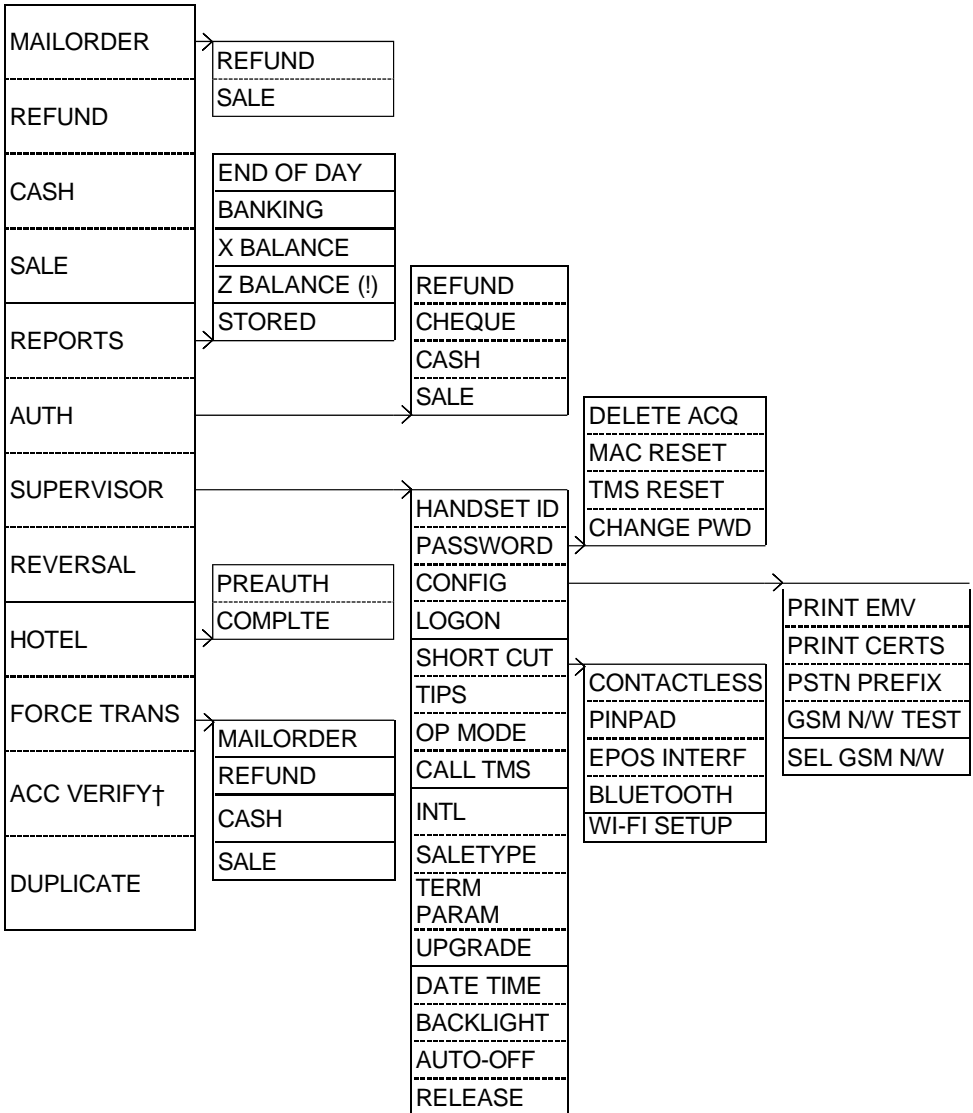

† if the ACC VERIFY option is not shown in the menu on your terminal then the Account Verification functionality is not available to you.

8. Notes

Certification

The CE marking certifies that the products from the iCT200 range (iCT220 and iCT250) comply with the essential requirements of the European Directive 1999/5/EC of 9 March 1999 on Radio and Telecommunications Terminal Equipment for:

- the protection of the health and safety of the user and any other person;
- the protection requirements with general respect to electromagnetic compatibility;

and comply with the following harmonised standards:

- iCT220/250 EN 60950-1
- iCT220/250 EN 55022 A1/A2
- iCT220/250 EN 55024 A1/A2
- iCT220/250 GPRS EN 60950-1
- iCT220/250 GPRS EN 301489-7
- iCT220/250 GPRS EN 301511
- iCT220/250 GPRS EN 50360
- iCT250 Contactless EN 60950-1
- iCT250 Contactless EN 301489-3
- iCT250 Contactless EN 300330-2

The whole range complies with the European approval specification on connecting terminal equipment (TE) with Dual Tone Multi Frequency (DTMF) dialling to the Public Switched Telephone Network (PSTN) (Council Decision 1998/482/EC, Council Decision 1999/303/EC):

- TS 103021-1/2/3
- TR 103000-1/2/3/4
- ES 201187

The manufacturer certifies that the products are manufactured in accordance with appendix iii of the R & TTE 1999/5/CE Directive.



Operating Environment

Your terminal (Class II Equipment) has the following electrical supply characteristics:

- Power Supply: 100-240 V (AC) 50-60 Hz
- Power Adapter: UK three pin 3 A plug
- Power Consumption: 800 mA (maximum)

Your Terminal is designed to be operated and stored at the following temperatures:

- Operating Temperature: +5°C to +45°C
- Operating Relative Humidity (maximum): 85% at +40°C
- Storage Temperature: -20°C to +55°C
- Storage Relative Humidity (maximum): 85% at +55°C

Copyright © 2016 Ingenico (UK) Ltd.

This User Guide (v1.1048) relates to terminal software APACS 40 97.11.01

Whilst every effort has been made to ensure that the content of this document is accurate, Ingenico will not accept responsibility for any loss, damage or injury that may be incurred as a result of any errors or inaccuracies. The product is varied to suit an acquirer's individual requirements and as such some features may vary or be disabled. This document should be accepted as a guide only to the use of the product.

In the effort for continued improvements in design and quality, products features and information regarding setting up, installation and use of all Ingenico products is subject to change without prior notice.



security



smartcard



magstripe



contactless



color display



connectivity